

SUPER DUTY STEERING STABILIZER KIT BY RANCHO SUSPENSION

READ ALL INSTRUCTIONS THOROUGHLY FROM START TO FINISH BEFORE BEGINNING INSTALLATION

1. Park the vehicle on a level surface and set the parking brake. Place the front wheels in a straightforward position by centering the steering wheel.
2. If applicable, remove the nuts and U-bolts holding the stabilizer bracket to the tie rod end (illustration 1). Remove the nut and bolt from the axle bracket (illustration 2). Remove the stabilizer assembly.
3. Extend new steering stabilizer RS5406 half way.
4. Attach tie rod bracket RS130022 to the new steering stabilizer with the mounting stud and supplied hardware. See illustration 3.
5. Attach the stabilizer assembly to the axle bracket with the new 12mm hardware.
6. Attach tie rod bracket RS130022 (with stabilizer) to the back of the tie rod end with the new U-bolts.
7. Tighten all nuts and bolts.
8. Turn wheels completely in both directions. Verify that the stabilizer shock does not bottom out and that there is no binding or interference with other components.

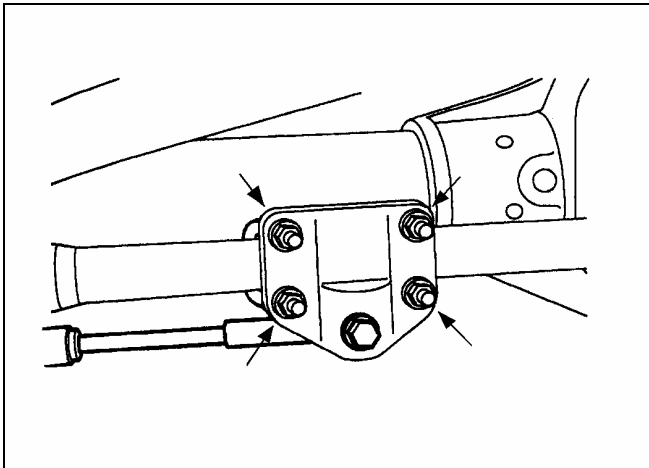

Illustration 1

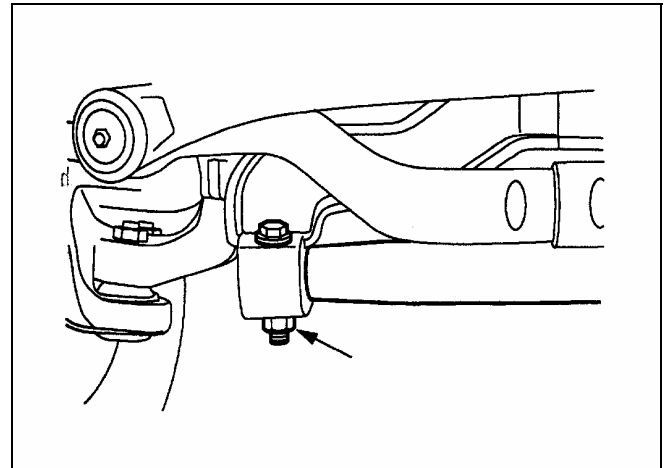

Illustration 2



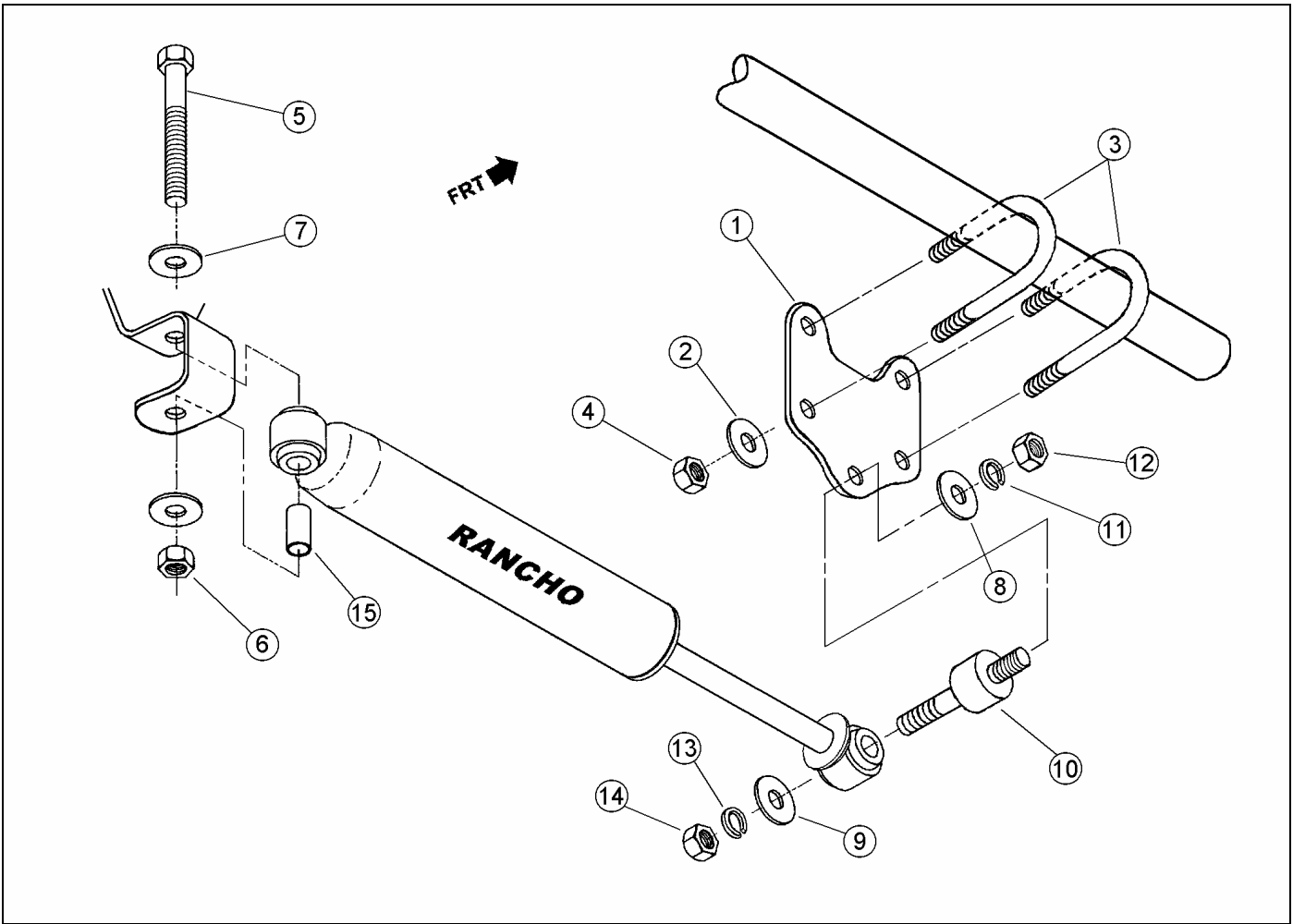

Illustration 3

RS5542 PARTS LIST

ITEM NO.	PART NO.	DESCRIPTION	QUANTITY
1	130022	Tie Rod Bracket	1
	860109	U-bolt Hardware Kit	1
2	603508	3/8 SAE Washer	4
3	7429	U-bolt	2
4	7604	3/8-16 Nyloc Nut	4
5	7690	M12-1.75x70mm HHCS	1
6	7807	M12-1.75 Nyloc Nut	1
7	7915	12mm Washer	2
	P00932	Parts Package	1
8	45480P	Mounting Pin Washer	1
9	45481P	Mounting Pin Washer	1
10	45559P	Mounting Stud	1
11	61803	Lock Washer	1
12	61804	1/2-20 Nut	1
13	GM120383	Lock Washer	1
14	GM271506	7/16-20 Nut	1
	P01013	Parts Package	1
15	60859H	Sleeve	1
	88037	Instruction	1
	94140	Consumer Information Pack	1