

INSTALLATION INSTRUCTIONS

8780

Rev A

FOR LEAF SPRING U-CLAMPS

READ ALL INSTRUCTIONS THOROUGHLY FROM START TO FINISH BEFORE BEGINNING INSTALLATION

NOTE: The purpose of the leaf spring U-clamp is NOT to hold the leaves against one another, but to prevent the lateral shifting or "fanning" of the leaves. The leaves are held together by the U-bolts and the center bolt. Install the U-clamp assembly **ONLY** on an installed leaf spring with properly tightened U-bolts.

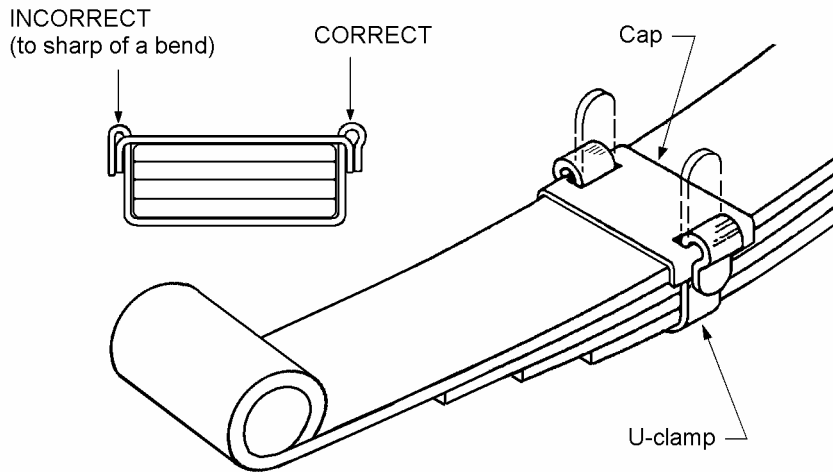

Install a U-clamp (from the bottom) over the leaves and at one of the leaf spring. Place a cap on top of the U-clamp as shown in the illustration. Repeat for other end.

Bend the tabs down over the sides of the caps while holding the U-clamp assemblies against the leaves. The bend should not be drastic, but should have somewhat of a curve to it (see illustration). Do Not force the leaves together with the U-clamp assemblies. *If extreme pressure is applied, the clamps will stiffen the ride and fail prematurely.*

DO NOT REUSE CLAMPS... A reshaped U-clamp may fail.

INSTALLATION INSTRUCTIONS

8780

Rev A

FOR LEAF SPRING U-CLAMPS

READ ALL INSTRUCTIONS THOROUGHLY FROM START TO FINISH BEFORE BEGINNING INSTALLATION

NOTE: The purpose of the leaf spring U-clamp is NOT to hold the leaves against one another, but to prevent the lateral shifting or "fanning" of the leaves. The leaves are held together by the U-bolts and the center bolt. Install the U-clamp assembly **ONLY** on an installed leaf spring with properly tightened U-bolts.

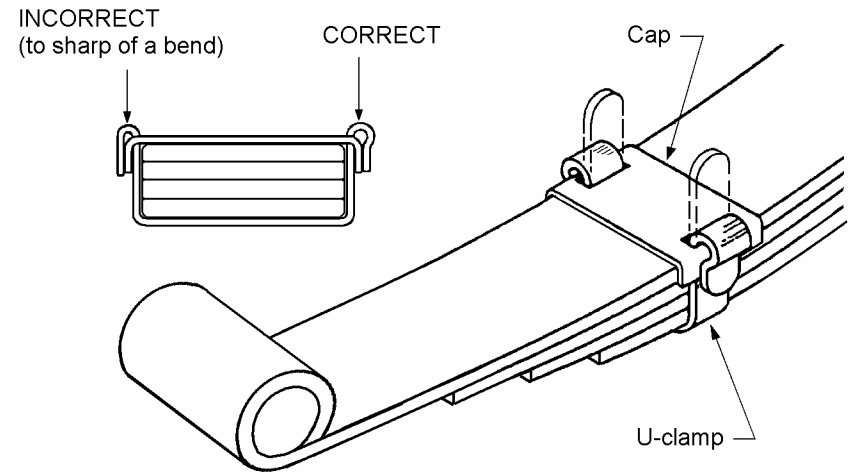

Install a U-clamp (from the bottom) over the leaves and at one of the leaf spring. Place a cap on top of the U-clamp as shown in the illustration. Repeat for other end.

Bend the tabs down over the sides of the caps while holding the U-clamp assemblies against the leaves. The bend should not be drastic, but should have somewhat of a curve to it (see illustration). Do Not force the leaves together with the U-clamp assemblies. *If extreme pressure is applied, the clamps will stiffen the ride and fail prematurely.*

DO NOT REUSE CLAMPS... A reshaped U-clamp may fail.