



Rancho **LEVEL IT** System – RS66902R9

Fits 2020-2027 Toyota Tundra 4WD

Excludes TRD PRO Models

READ ALL INSTRUCTIONS THOROUGHLY FROM START TO FINISH BEFORE BEGINNING INSTALLATION

Fits 275/65R20 or 285/70 R18 Tires on OE or 9" wide +25 offset wheel with 6" of backspacing .

Trimming may be required. Trimming or removal of mud flaps may be required

Before installing any other size tire, consult your local tire and wheel specialist.

⚠ WARNING: Carefully read, understand and follow the instructions provided in this manual, and keep it in a safe place for future reference. If you have any doubt whatsoever regarding the installation or maintenance of your Rancho suspension system, please see your retailer for assistance or advice. Failure to follow the warnings and instructions provided herein can result in the failure of the suspension system, or can cause you to lose control of your vehicle, resulting in an accident, severe personal injury or death.

These instructions should remain in the vehicle glove box for future reference

Parts List

P/N	DESCRIPTION	QTY.
RS999759UMM	Rancho QuickLIFT Strut	2
RS176805	0.75" Slotted Sway Bar Spacer	2
RS860807	Hardware Kit	1
RS770280	HHCS, M12-1.25X55MM	4
RS7915	Washer, M12	4
RS94180	Information Pack	1
RS89902	Instructions	1

STRUT REMOVAL

1) Park the vehicle on a level surface. Set the parking brake and chock rear wheels. Measure and record the distance from the center of each wheel to the top of the fender opening. Record these measurements in the space provided.

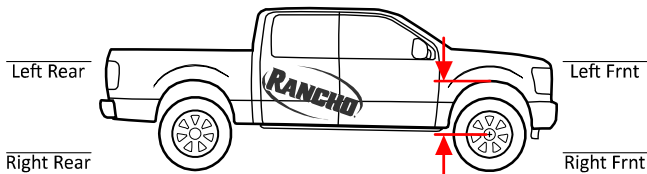

2) Raise the front of the vehicle and support the frame with jack stands. Remove the front wheels and set them aside.

3) Remove front skid plate if equipped. See Illustration 1

4) Remove sway bar mounts at frame. Allow sway bar to hang down from end links. See Illustration 2.

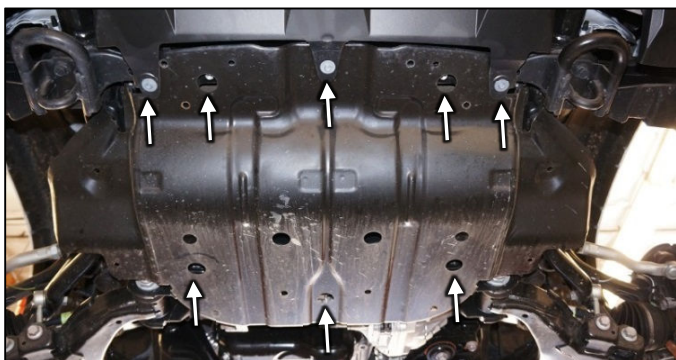

Illustration 1

5) Remove brake hose and ABS wire brackets from steering knuckle, frame, and upper control arm. See Illustration 3.

6) Remove cotter pin and loosen outer tie rod stud nut. Using appropriate puller, separate then remove tie rod stud from steering knuckle. See Illustration 4

7) Remove cotter pin and loosen but do not remove upper ball joint stud nut. Using appropriate puller, separate upper ball joint stud from steering knuckle. See Illustration 4

⚠ WARNING: CONTROL ARM WILL SPRING UP WITH GREAT FORCE WHEN BALL JOINT SEPARATES FROM KNUCKLE. USE PRY BAR TO HOLD DOWN AND SLOWLY LIFT BALL JOINT STUD OUT OF KNUCKLE WHEN REMOVING BALL JOINT STUD NUT.

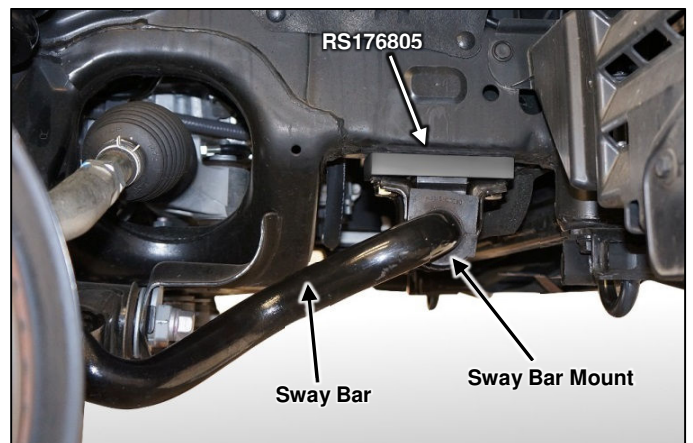

Illustration 2

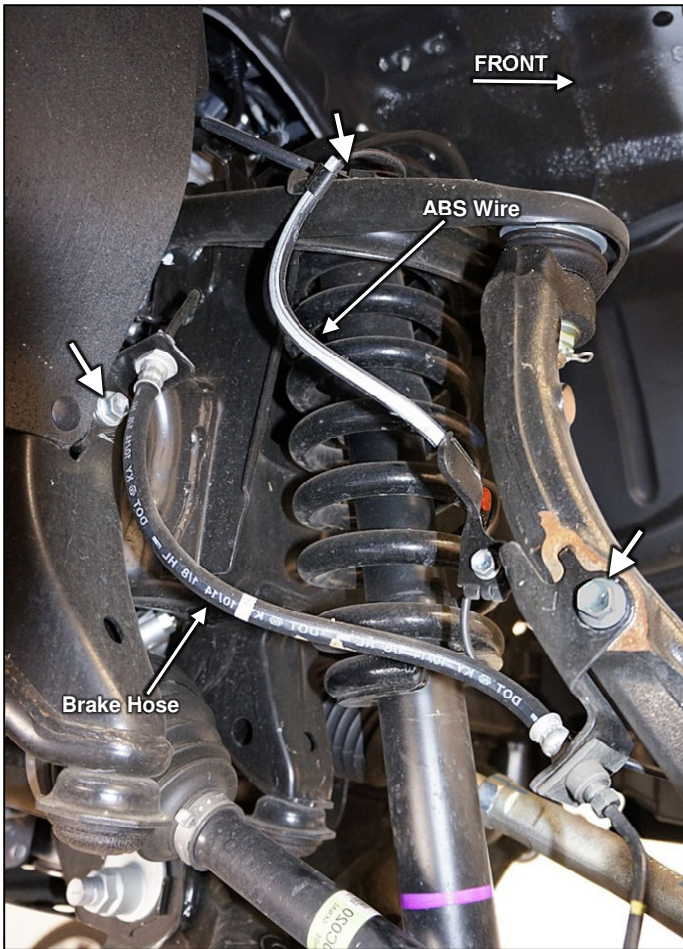

Illustration 3

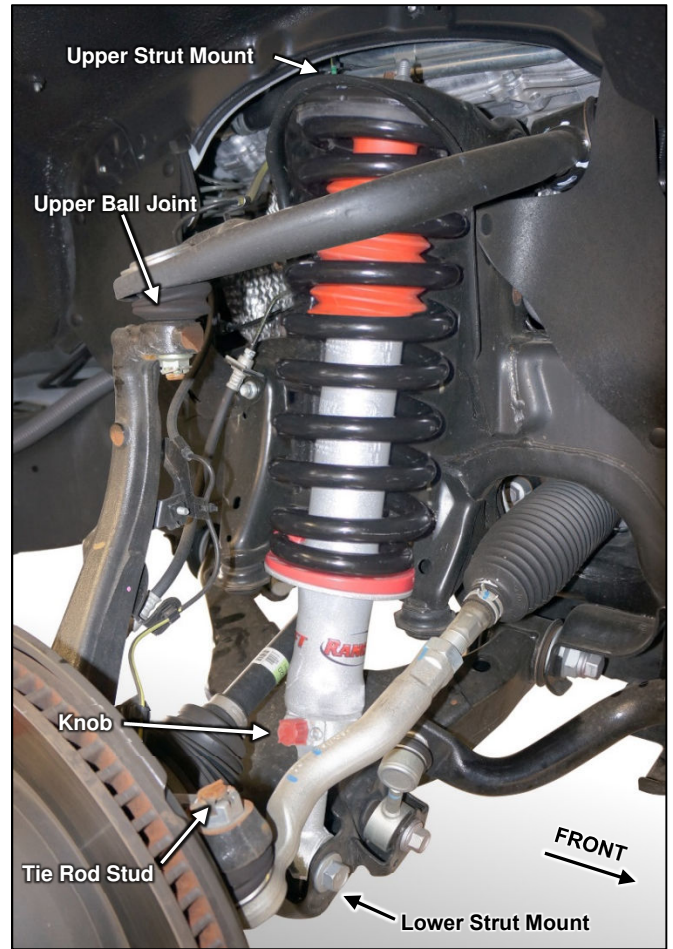

Illustration 4

8) Pry down on upper control arm, remove ball joint nut, and remove ball joint stud from knuckle.

9) Support lower control arm with jack.

10) Remove upper strut mounting nuts. See Illustration 4

CAUTION: DO NOT TURN STRUT'S CENTER ROD NUT!

11) Remove lower strut mounting bolt. See Illustration 4

12) Remove strut from vehicle. Lower jack if required. If required pry strut out of lower mount.

CAUTION: Take care not to damage CV boot, or pull CV out of housing.

STRUT REPLACEMENT

1) Reference mark top mount, coil spring and strut. See Illustration 5.

2) Using a suitable spring compressor tool, compress spring slightly to relieve initial tension.

⚠ WARNING: SPRING IS UNDER COMPRESSION LOAD WHEN INSTALLED. ATTEMPTS TO REMOVE SPRING WITHOUT PROPERLY RESTRAINING THIS LOAD MAY RESULT IN INJURY. NEVER REMOVE THE CENTRAL LOCK NUT OF THE UPPER MOUNTING PARTS BEFORE THE SPRING IS COMPRESSED.

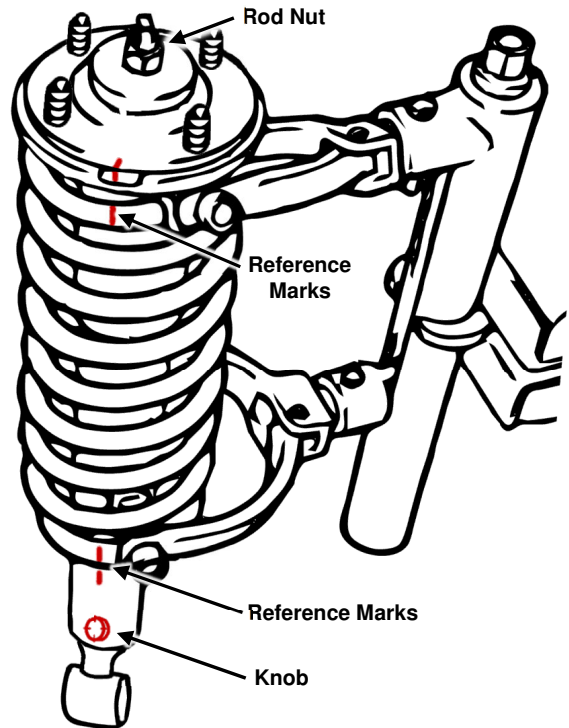

Illustration 5

IF A SUITABLE SPRING COMPRESSOR TOOL IS NOT AVAILABLE, OR A QUALIFIED OPERATOR IS NOT AVAILABLE, MOST REPAIR SHOPS CAN SWAP THE STRUT FOR A SMALL CHARGE.

3) With initial spring tension relieved, loosen rod nut slightly. Compress spring until loose from lower spring seat and then completely remove nut. See Illustration 5.

4) Remove all upper mounting parts and spring from strut assembly; save for reuse. Note position of all parts as removed to ensure proper installation of replacement parts. Inspect all original parts as removed for wear and damage. Obtain replacements when necessary.

5) Install supplied lower spring seat and retainer on new Rancho strut.

CAUTION: Follow instructions and warnings supplied with strut.

6) Install strut on spring and upper mount assembly. Spring may need to be compressed more to fit new Rancho strut. Tighten center rod nut to OE specifications.

⚠ WARNING: DO NOT OVER TIGHTEN ROD NUT. EXCESSIVE TORQUE CAN DAMAGE THE THREADS ON THE NUT OR PISTON ROD. USE TORQUE VALUE FROM OE MANUFACTURER.

7) Using reference marks, align upper mount assembly, spring and strut with knob facing out and slowly decompress spring. See Illustration 4 See and Illustration 5.

NOTE: Knob faces to outside of vehicle

8) Loosely install strut in upper mount using OE hardware.

9) Pry lower strut bushing into position and attach to lower control arm using OE hardware. Lower jack if required Tighten upper and lower strut mounting hardware to OE specifications.

CAUTION: Take care not to damage CV boot, or pull CV out of housing.

10) Pry down upper control arm and attach upper ball joint stud to steering knuckle using OE hardware. Tighten hardware to OE specifications. Install NEW cotter pins, tightening ball joint nuts as needed to align castle nut with hole.

DO NOT LOOSEN BALL JOINT NUT TO INSTALL COTTER PIN!

11) Attach outer tie rod end to steering knuckle with OE hardware. Tighten hardware to OE specifications. Install NEW cotter pins, tightening ball joint nuts as needed to align castle nut with hole.

DO NOT LOOSEN BALL JOINT NUT TO INSTALL COTTER PIN!

12) Re-install brake hose and ABS wire brackets in original locations.

SWAY BAR SPACER INSTALLATION

1) Loosely install driver side sway bar mount with spacer RS176805 between mount and frame. Use supplied M12-hardware. See Illustration 2.

2) Install passenger side sway bar mount with spacer RS176782 between mount and frame.

3) Torque hardware to OE specifications.

4) Install front wheels and lower vehicle to ground. Tighten lug nuts to specifications.

FINAL CHECKS & ADJUSTMENTS

1) Turn the front wheels completely left then right. Verify adequate tire, wheel, and brake hose clearance. Inspect steering and suspension for tightness and proper operation.

2) With the suspension at maximum extension (full droop), inspect and rotate all axles and drive shafts.

3) Ensure that the vehicle brake system operates correctly.

4) Readjust headlamps and have vehicle aligned at a certified alignment facility.

Recommended Alignment Specifications

Caster (degrees): $2.70^{\circ} \pm .75^{\circ}$

Camber (degrees): $0.23^{\circ} \pm 0.75^{\circ}$

Sum Toe In (degrees): $0.2^{\circ} \pm 0.2^{\circ}$ or $0.10'' \pm 0.10''$

5) Measure and record the distance from the center of each wheel to the top of the fender opening. Record these measurements in the space provided.

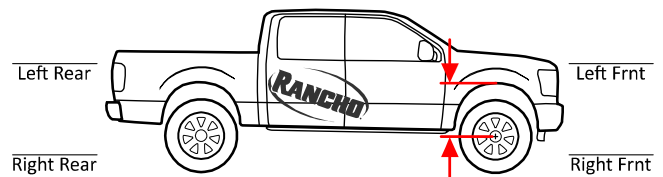

Vehicle Torque Specifications

Strut Rod Nut	18 lb-ft.
Upper Strut Mounting Nuts	33 lb-ft.
Lower Strut Mounting Bolt	144 lb-ft.
Tie Rod End Ball Stud Nut	67 lb-ft.
Upper Ball Joint Nut	81 lb-ft.
Sway Bar Mounting Bolts	51 lb-ft.
Sway Bar End Link to Control Arm	89 lb-ft.
Sway Bar End Link to Sway Bar	111 lb-ft.
Brake Line Bracket to Steering Knuckle	21 lb-ft.
ABS Wire Bracket to Upper Control Arm	9 lb-ft.
Wheel Lug Nuts Aluminum Wheel	97 lb-ft.
Wheel Lug Nuts Steel Wheel	154 lb-ft.

⚠ WARNING: READ ALL INSTRUCTIONS THOROUGHLY FROM START TO FINISH BEFORE BEGINNING INSTALLATION. Failure to follow the warnings and instructions provided herein can result in an accident, severe personal injury or death.

PRELIMINARY

This manual presumes that all persons installing this suspension system have a high level of mechanical training and experience, and have available to them all necessary tools and safety equipment. This manual is not and should not be construed as an exhaustive list of all required safety measures. Personnel should rely primarily on their training and experience, as well as on their own common sense.

This Manual is to be read as a supplement to, and must not be construed as a substitute for, the owner's manual and/or shop manual that originally accompanied the vehicle. Refer to such use, operation, maintenance and safety manuals as necessary, and especially after installation is complete, to insure proper vehicle operation.

The following terminology has been used in this Manual:

ACCIDENT: Any event which could cause personal injury or death to anyone installing or using the suspension system, as well as to passengers and bystanders, or otherwise may result in property damage.

PRE-INSTALLATION WARNINGS and INSTRUCTIONS

⚠ WARNING: This suspension system will enhance the off-road performance of your vehicle. It will handle differently; both on and off-road, from a factory equipped passenger car or truck. Failure to drive this vehicle safely may result in serious injury or death to the driver and passengers. ALWAYS WEAR your seat belts, REDUCE your speed, and AVOID sharp turns and other abrupt maneuvers.

- Service and repair tasks require specialized knowledge, training, tools, and experience. General mechanical aptitude may not be sufficient to properly install this suspension system. If you have any doubt whatsoever regarding your ability to properly install the suspension system, please consult a qualified mechanic.
- Your brake lines and fuel lines should remain undisturbed during and after installation. If you think you need to modify these components in any way, you are mistaken. You are installing the kit improperly and will be creating a significant risk of an accident. In case of any doubt, consult a qualified mechanic.
- If any component does not fit properly, something is wrong. You are installing the kit improperly and will be creating a significant risk of an accident. Never modify any component of the vehicle or suspension system, except as instructed herein. Do not continue with installation until you have identified the problem.
- Several of the procedures described herein require at least two (2) persons to safely complete the task. If you have any doubt about your ability to complete any operation by yourself, always ask for help from a qualified assistant.
- Before starting any operation, confirm that all personal safety devices and safety equipment are in proper condition and position.
- Give your work undivided attention. Looking around, carrying on a conversation and "horse-play" are careless acts that can result in an error in installation and/or serious injury.
- Install only tires approved by the United States Department of Transportation ("DOT approved"). Make sure the rim and tire size are properly matched.
- If any components of the vehicle or suspension system are damaged in any way during installation, immediately replace the component.
- During installation, carefully inspect all parts of the vehicle and replace anything that is worn or damaged.

Standard Bolt Torque and Identification

INCH SYSTEM			
Bolt Size	Grade 5	Grade 8	
5/16	15 LB-FT	20 LB-FT	
3/8	30 LB-FT	35 LB-FT	
7/16	45 LB-FT	60 LB-FT	
1/2	65 LB-FT	90 LB-FT	
9/16	95 LB-FT	130 LB-FT	
5/8	135 LB-FT	175 LB-FT	
3/4	185 LB-FT	280 LB-FT	
METRIC SYSTEM			
Bolt Size	Class 8.8	Class 10.9	Class 12.9
M6	5 LB-FT	9 LB-FT	12 LB-FT
M8	18 LB-FT	23 LB-FT	27 LB-FT
M10	32 LB-FT	45 LB-FT	50 LB-FT
M12	55 LB-FT	75 LB-FT	90 LB-FT
M14	85 LB-FT	120 LB-FT	145 LB-FT
M16	130 LB-FT	165 LB-FT	210 LB-FT
M18	170 LB-FT	240 LB-FT	290 LB-FT

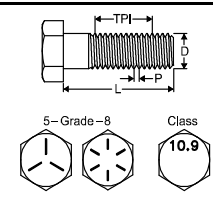

1/2-13x1.75 HHCS
 $\frac{D}{TPI}$ $\frac{L}{X}$

M12-1.25x50 HHCS
 $\frac{D}{P}$ $\frac{L}{X}$

D = Nominal Diameter
TPI = Threads Per Inch
P = Pitch (Thread Width, mm)
L = Length
X = Description (Hex Head Cap Screw)

10) Nip points present the risk of the catching, lacerating, crushing and/or amputating fingers, hands, limbs and other body parts during operations. Always keep clear. Wear protective gloves.

11) Oil and hydraulic fluids are poisonous, dangerous to health and are known to the State of California to cause cancer, birth defects or other reproductive harm. Do not inhale vapors or swallow. Do not allow contact with the eyes or skin. Should any oil or fluids be swallowed or inhaled or come into contact with the eyes, immediately follow the safety precautions on the label or call a poison control center immediately. Should any of the oil or fluids contact your skin, immediately wash thoroughly.

12) Never install the suspension system if you are under the effects of alcohol, medications and/or drugs. If you are taking prescription or over the counter medication, you must consult a medical professional regarding any side effects of the medication that could hinder your ability to work safely.

AFTER INSTALLATION WARNINGS and INSTRUCTIONS

13) After installation is complete, drive the vehicle slowly in an area free from heavy traffic for at least three (3) miles. Likewise, before traveling on any highways or at a high rate of speed, drive the vehicle for ten (10) miles on side roads at moderate speed. If you hear any strange noise or feel unusual vibration, if a component of the suspension system is not operating properly, or if any warning lights illuminate or buzzers sound, stop the vehicle immediately. Identify the cause and take any necessary remedial action.

14) Confirm that all components of the vehicle, including all lights (headlights, turn signals, brake lights, etc.), linkages (accelerator, etc.), electrical switches and controls (windshield wipers and defoggers, etc.), and other warning devices (low tire pressure monitoring systems) are fully operational.

15) Your headlights will need to be readjusted before the vehicle is used on the roads. Consult the vehicle owners' manual.

16) The speedometer and odometer will need to be recalibrated after installation. See your dealer.

17) Confirm proper rear view and side view while seated in the driver seat. Install supplemental mirrors as necessary.

18) Your original low tire pressure monitoring system may be re-installed in your new wheels. However, if you choose to purchase a new system, see your dealer to have them properly calibrated. Proper tire pressure is critical to safe operation of the vehicle.

OPERATION

19) Because it has been modified, the vehicle will not handle, turn, accelerate or stop in the same manner as an unmodified vehicle. In addition, the crash protection systems designed in the vehicle may operate differently from an unmodified vehicle. For example, turning and evasive maneuvers must be executed at a slower rate of speed. Further, there is a greater risk that the vehicle could roll over. These differences could result in an increased possibility of an accident, personal injury or death. Learn the vehicle's operations and handling characterizes and drive accordingly.

⚠ The driver of this suspension system recognizes and agrees that there are risks inherent in driving a vehicle with a modified suspension system, including but not limited to the risk that you could be involved in an accident that would not occur in an unmodified vehicle. By his/her purchase and use of this suspension system, the user expressly, voluntarily and knowingly accepts and assumes these risks, and agrees to hold DRIV, Inc. and its related companies harmless to the fullest extent permitted by law against any resulting damages.



Rancho Technical Department 1-800-325-8886