

# INSTALLATION INSTRUCTIONS



## **For Rancho Suspension System RS66553B:**

2017-2011 Ford F250 / F350 Super Duty 4x4

2.5" Leveling Kit

(Available in black only. Component in illustrations may be red for illustrative purpose)

**— DIESEL ONLY —**

(WILL NOT WORK ON GAS ENGINES DUE TO EXHAUST CLEARANCE ISSUES).



Ford Super Duty

READ ALL INSTRUCTIONS THOROUGHLY FROM START TO FINISH BEFORE BEGINNING INSTALLATION

**IMPORTANT NOTES!**

**WARNING:** This suspension system will enhance the off-road performance of your vehicle. It will handle differently, both on and off-road, from a factory equipped passenger car or truck. Failure to drive this vehicle safely may result in serious injury or death to the driver and passengers. ALWAYS WEAR your seat belts, REDUCE your speed, and AVOID sharp turns and other abrupt maneuvers.

A. Before installing this system, have the vehicle's alignment and frame checked by a certified technician. The alignment must be within factory specifications and the frame of the vehicle must be sound (no cracks, damage or corrosion).

B. The components of Rancho's suspension system are designed as a single integrated system. To avoid compromises in terms of safety, performance, durability or function, do not substitute Rancho components with components manufactured by other companies. Use of other components will result in the forfeiture of any type of warranty on the vehicle/suspension system. New Rancho 5ront shock absorbers are required and must be purchased separately.

FRONT 2017-2011 <sup>1</sup>	REAR 2016-2011 <sup>2</sup>	REAR 2017 <sup>2</sup>
RS999043 <sup>XL</sup>	RS999254 <sup>XL</sup>	
RS7043	RS7254	
RS55043	RS55254	RS55047A
RS5043	RS5254	

<sup>1</sup> Required

<sup>2</sup> Optional

C. Do not powdercoat or plate any of the components in this system. To change the appearance of components, automotive paint can be applied over the original coating. Actual color of components may differ from illustrations.

D. Each hardware kit in this system contains fasteners of high strength and specific size. Do not mix hardware kits or substitute a fastener of lesser strength. See bolt identification table on page 3.

E. Compare the contents of this system with the parts list in these instructions. If any parts are missing, contact the Rancho Technical Department at 1-734-384-7804.

F. Install all nuts and bolts with a flat washer. When both SAE (small OD) and USS (large OD) washers are used in a fastener assembly, place the USS washer against the slotted hole and the SAE washer against the round hole.

G. Apply a drop of thread locking compound to all bolts during installation. CAUTION: Thread locking compound may irritate sensitive skin. Read warning label on container before use.

H. Unless otherwise specified, tighten all nuts and bolts to the standard torque specifications shown in the table on page 3. USE A TORQUE WRENCH for accurate measurements.

I. Some of the service procedures require the use of special tools designed for specific procedures. The following tools and supplies are recommended for proper installation of this system:

- Ford Service Manual
- Right Angle Drill
- 9/32" Drill
- Torque Wrench (250 FT-LB capacity)
- 1/2" Drive Ratchet and Sockets
- 1/2" Drive Breaker Bar
- Combination Wrenches
- Heavy Duty Jack Stands
- Hydraulic Floor Jack (2)
- Wheel Chocks (wooden blocks)
- Center Punch
- Hammer
- Wire Brush (to clean bracket mounting surfaces)
- Tape Measure
- Safety Glasses**--Wear safety glasses at all times

J. Suspension components that use rubber or urethane bushings should be tightened with the vehicle at normal ride height. This will prevent premature failure of the bushing and maintain ride comfort.

L. This suspension system was developed using the following tire & wheel combination: BFGoodrich® All-Terrain™ 35x12.5R17/D tire, 17" wheel with 6.25" of backsparing. Before installing any other combination, consult your local tire and wheel specialist. Actual tire size varies by manufacturer.

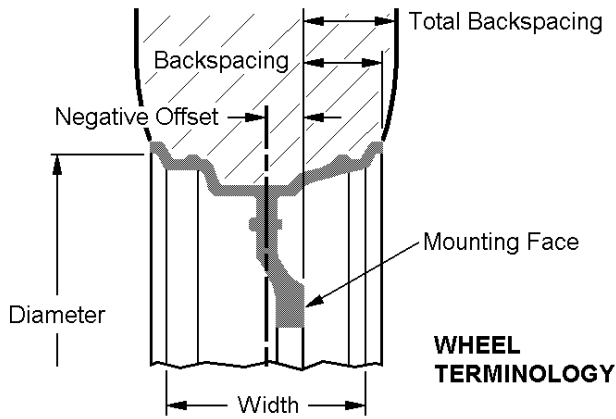

M. The required installation time for this system is approximately 3 to 4 hours. Check off the box (  ) at the beginning of each step when you finish it. Then when you stop during the installation, it will be easier to find where you need to continue from.

N. Important information for the end user is contained in the consumer/installer information pack. If you are installing this system for someone else, place the information pack on the driver's seat. Please include the installation instructions when you finish.

O. Thank you for purchasing the best suspension system available. For the best installed system, follow these instructions. If you do not have the tools or are unsure of your abilities, have this system installed by a certified technician. RANCHO IS NOT RESPONSIBLE FOR DAMAGE OR FAILURE RESULTING FROM IMPROPER INSTALLATION OF THIS SUSPENSION SYSTEM.

**STANDARD BOLT TORQUE & IDENTIFICATION**

INCH SYSTEM			METRIC SYSTEM			
Bolt Size	Grade 5	Grade 8	Bolt Size	Class 9.8	Class 10.9	Class 12.9
5/16	15 FT-LB	20 FT-LB	M6	5 FT-LB	9 FT-LB	12 FT-LB
3/8	30 FT-LB	35 FT-LB	M8	18 FT-LB	23 FT-LB	27 FT-LB
7/16	45 FT-LB	60 FT-LB	M10	32 FT-LB	45 FT-LB	50 FT-LB
1/2	65 FT-LB	90 FT-LB	M12	55 FT-LB	75 FT-LB	90 FT-LB
9/16	95 FT-LB	130 FT-LB	M14	85 FT-LB	120 FT-LB	145 FT-LB
5/8	135 FT-LB	175 FT-LB	M16	130 FT-LB	165 FT-LB	210 FT-LB
3/4	185 FT-LB	280 FT-LB	M18	170 FT-LB	240 FT-LB	290 FT-LB

<p><b>1/2-13x1.75 HHCS</b></p> <p>D T L X</p> <p>G = Grade Marking (bolt strength) D = Nominal Diameter (inches) T = Thread Pitch (threads per inch)</p>	<p>Grade 5 Grade 8</p> <p>L = Length (inches) X = Description (hex head cap screw)</p>		<p><b>M12-1.25x50 HHCS</b></p> <p>D T L X</p> <p>P = Property Class (bolt strength) D = Nominal Diameter (millimeters) T = Thread Pitch (thread width, mm)</p>	<p>P -10.9</p> <p>L = Length (millimeters) X = Description (hex head cap screw)</p>	
--	--	--	--	---	--



## PARTS LIST

P/N	DESCRIPTION	QTY.
RS66553B-1	Box 1 of 2	1
RS176320B	Left Radius Arm	1
RS176321B	Right Radius Arm	1
RS176322	Bump Stop Spacer	2
RS176420	Brake Line Bracket	2
RS860513	Hardware Kit – Bump Stop	1
RS770124	M8-1.25 x 95 HHCS	2
RS603112	M8-1.25 Nyloc Nut	2
RS7642	SAE Washer	2
RS7733	USS Washer	2
RS770118	M18-2.5 Nyloc Nut	1
RS42702	Thread Lock	2
136763624	Tie Wrap	5

P/N	DESCRIPTION	QTY.
RS860516	Hardware Kit – Brake Line Bracket	1
RS770127	M8-1.25 x 25 HHCS	2
RS603112	M8-1.25 Nyloc Nut	2
RS770128	8mm Washer	4
RS42702	Thread Lock	2
136763624	Tie Wrap	6
RS94180	Information Pack	1
RS780281	Rancho Decal	1
RS89553	Instructions	1
RS94119	Consumer/Warranty Information	1
RS94177	Warning Sticker	1
RS66553B-2	Box 2 of 2	1
RS697B	Front Leveling Coil	2

## FRONT SUSPENSION

### Vehicle Preparation

1.  Park the vehicle on a level surface. Set the parking brake and chock rear wheels.
2.  Disconnect the sway bar end links from the sway bar and axle brackets. See illustration 1. Save all hardware.
3.  Raise the front of the vehicle and support the frame with jack stands. Remove front wheels and set them aside.

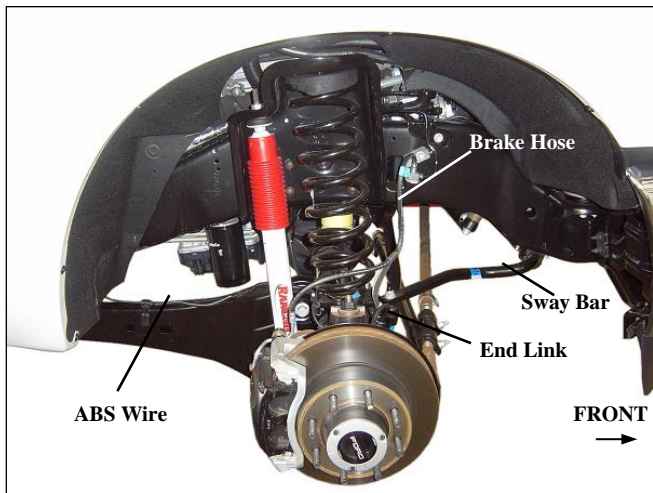

Illustration 1

4. Disconnect the ABS sensor wire from the lower spring seat and the radius arm.
5.  If equipped, disconnect the vacuum hose from the axle hub and frame.
6.  Repeat steps 4 and 5 for the other side.

### Radius Arm Removal & Installation

1.  Support the front axle with two floor jacks, one under each coil spring.
2.  Remove the front shock absorbers. Carefully lower the axle enough to relieve the tension on the coil springs.

**CAUTION:** Do not allow the front axle to hang from any cables, lines or hoses.

3.  Using a ratchet and deep socket remove the bolt that holds the lower spring seat to the axle. See illustration 2. Remove the coil spring and lower seat as an assembly. Repeat for other side.



Illustration 2

4.  Support both radius arms with jack stands. Remove the rear mounting bolts and lower the radius arms out of the frame brackets.

**CAUTION:** Always support at least one radius arm with a jack stand to keep the axle from rotating downward.

5.  Remove the driver side radius arm from the front axle.
6.  Loosely attach left radius arm RS176320 to the front axle on the driver side. Use the original hardware and the 18mm nut from kit RS860513. See illustration 3.

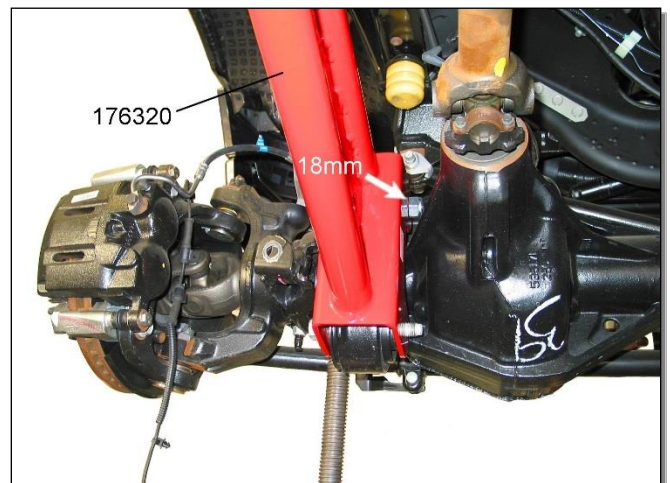

Illustration 3



7.  Remove the passenger side radius arm from the front axle.
8.  Loosely attach right radius arm RS176321 to the front axle on the passenger side. Use the original hardware.
9.  Lift radius arms into frame brackets. Install the original bolts and nuts. Do not tighten until vehicle is at normal ride height.

### **Bump Stop Spacer Installation**

1.  Remove bump stop from frame bracket. Remove bracket from frame rail.
2.  Insert spacer RS176322 between frame rail and bracket. See illustration 4. Align tab on bracket with hole in spacer. Attach bump stop bracket to spacer and frame rail with the 8 mm bolt and smaller washer from kit RS860513. Tighten bolt.

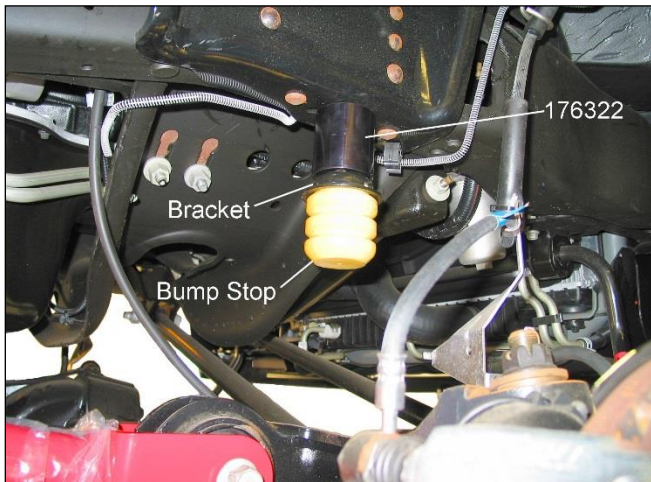

Illustration 4

3.  Install the larger washer and 8mm nut on top. Tighten nut.
4.  Insert bump stop into bracket.
5.  Repeat steps 1 through 4 for the other side.

### **Coil Spring Installation**

1.  Install original rubber washer on top of coil spring RS697 or RS699. Align pigtail and install lower spring seat on bottom of coil spring.
2.  Insert coil spring assembly into upper bracket and onto front axle. Reattach lower spring seat.
3.  Repeat steps 1 and 2 for the other side.
4.  Carefully raise axle until springs are snug. Install new front shock absorbers (RS99043, RS7043, RS5043, or RS55043)).

*CAUTION:* Do not lift the vehicle off of jack stands.

5.  Reattach the brake line brackets to the lower spring seats. If applicable, reconnect the vacuum hose to the axle hub.

*NOTE:* Readjust vacuum hose clips as necessary.

6.  Reconnect the ABS wires to the lower spring seat. Attach wires to radius arms with tie wraps. See illustration 5.

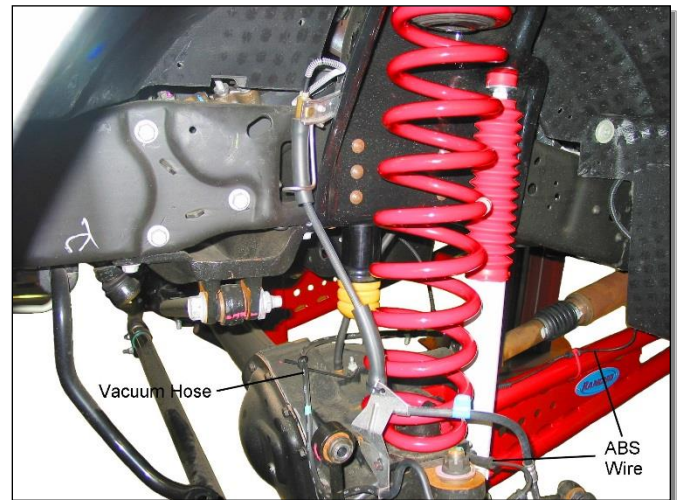

Illustration 5

## **Brake Hose Drop Bracket installation**

1.  Attach brake hose to drop bracket RS176420 with the hardware from kit RS860516. See illustration 6.



Illustration 6

2.  Using the original bolt and location, attach brake hose drop bracket RS1765420 to the frame rail. Tighten nuts and bolts securely.
3.  Repeat for other side.

## **FINAL CHECKS & ADJUSTMENTS**

1.  Turn the front wheels completely left then right. Verify adequate tire, wheel, and brake hose clearance. Inspect steering and suspension for tightness and proper operation.
2.  Ensure that the vehicle brake system operates correctly. If new brake hoses were installed, verify that each hose allows for full suspension movement.
3.  Readjust headlamps. Have vehicle Aligned at a certified alignment facility.

**Please retain this publication for future reference.  
See Important Note M.**

---