



Rancho Suspension Systems **RS66454R9**

2017-2014 Dodge Ram 2500 2 1/2" Leveling Kit

Includes Rancho RS9000 Front Shock Absorbers



Fits OE rims and spare

Fits up to:
BFG KM2 35X12.5R17 Tires
On 17 x 9 x 5.5 Backspacing Wheel

⚠ WARNING

Carefully read, understand and follow the instructions provided in this manual, and keep it in a safe place for future reference. If you have any doubt whatsoever regarding the installation or maintenance of your Rancho suspension system, please see your retailer for assistance or advice. Failure to follow the warnings and instructions provided herein can result in the failure of the suspension system, or can cause you to lose control of your vehicle, resulting in an accident, severe personal injury or death.

These instructions should remain in the vehicle glove box for future reference.

⚠ WARNING: READ ALL INSTRUCTIONS THOROUGHLY FROM START TO FINISH BEFORE BEGINNING INSTALLATION. Failure to follow the warnings and instructions provided herein can result in an accident, severe personal injury or death.

PRELIMINARY

This manual presumes that all persons installing this suspension system have a high level of mechanical training and experience, and have available to them all necessary tools and safety equipment. This manual is not and should not be construed as an exhaustive list of all required safety measures. Personnel should rely primarily on their training and experience, as well as on their own common sense.

This Manual is to be read as a supplement to, and must not be construed as a substitute for, the owner's manual and/or shop manual that originally accompanied the vehicle. Refer to such use, operation, maintenance and safety manuals as necessary, and especially after installation is complete, to insure proper vehicle operation.

The following terminology has been used in this Manual:

ACCIDENT: Any event which could cause personal injury or death to anyone installing or using the suspension system, as well as to passengers and bystanders, or otherwise may result in property damage.

PRE-INSTALLATION WARNINGS and INSTRUCTIONS

⚠ WARNING: Only the following rim/tire sizes may be used with this suspension system: 35X12.50R17, 17 x 9 x 5.5 Backspacing Rim

Use of any other rim/tire combination increases the risk of a roll-over and/or accident, resulting in severe personal injury or death.

⚠ WARNING: This suspension system will enhance the off-road performance of your vehicle. It will handle differently; both on and off-road, from a factory equipped passenger car or truck. Failure to drive this vehicle safely may result in serious injury or death to the driver and passengers. ALWAYS WEAR your seat belts, REDUCE your speed, and AVOID sharp turns and other abrupt maneuvers.

- 1) Service and repair tasks require specialized knowledge, training, tools, and experience. General mechanical aptitude may not be sufficient to properly install this suspension system. If you have any doubt whatsoever regarding your ability to properly install the suspension system, please consult a qualified mechanic.
- 2) Your brake lines and fuel lines should remain undisturbed during and after installation. If you think you need to modify these components in any way, you are mistaken. You are installing the lift improperly and will be creating a significant risk of an accident. In case of any doubt, consult a qualified mechanic.
- 3) If any component does not fit properly, something is wrong. You are installing the lift kit improperly and will be creating a significant risk of an accident. Never modify any component of the vehicle or suspension system, except as instructed herein. Do not continue with installation until you have identified the problem.
- 4) Several of the procedures described herein require at least two (2) persons to safely complete the task. If you have any doubt about your ability to complete any operation by yourself, always ask for help from a qualified assistant.
- 5) Before starting any operation, confirm that all personal safety devices and safety equipment are in proper condition and position.
- 6) Give your work undivided attention. Looking around, carrying on a conversation and "horse-play" are careless acts that can result in an error in installation and/or serious injury.

7) Install only tires approved by the United States Department of Transportation ("DOT approved"). Make sure the rim and tire size are properly matched.

8) If any components of the vehicle or suspension system are damaged in any way during installation, immediately replace the component.

9) During installation, carefully inspect all parts of the vehicle and replace anything that is worn or damaged.

10) Nip points present the risk of the catching, lacerating, crushing and/or amputating fingers, hands, limbs and other body parts during operations. Always keep clear. Wear protective gloves.

11) Oil and hydraulic fluids are poisonous, dangerous to health and are known to the State of California to cause cancer, birth defects or other reproductive harm. Do not inhale vapors or swallow. Do not allow contact with the eyes or skin. Should any oil or fluids be swallowed or inhaled or come into contact with the eyes, immediately follow the safety precautions on the label or call a poison control center immediately. Should any of the oil or fluids contact your skin, immediately wash thoroughly.

12) Never install the suspension system if you are under the effects of alcohol, medications and/or drugs. If you are taking prescription or over the counter medication, you must consult a medical professional regarding any side effects of the medication that could hinder your ability to work safely.

AFTER INSTALLATION WARNINGS AND INSTRUCTIONS

13) After installation is complete, drive the vehicle slowly in an area free from heavy traffic for at least three (3) miles. Likewise, before traveling on any highways or at a high rate of speed, drive the vehicle for ten (10) miles on side roads at moderate speed. If you hear any strange noise or feel unusual vibration, if a component of the suspension system is not operating properly, or if any warning lights illuminate or buzzers sound, stop the vehicle immediately. Identify the cause and take any necessary remedial action.

14) Confirm that all components of the vehicle, including all lights (headlights, turn signals, brake lights, etc.), linkages (accelerator, etc.), electrical switches and controls (windshield wipers and defoggers, etc.), and other warning devices (low tire pressure monitoring systems) are fully operational.

15) Your headlights will need to be readjusted before the vehicle is used on the roads. Consult the vehicle owners' manual.

16) The speedometer and odometer will need to be recalibrated after installation. See your dealer.

17) Confirm proper rear view and side view while seated in the driver seat. Install supplemental mirrors as necessary.

18) Your original low tire pressure monitoring system may be re-installed in your new wheels. However, if you choose to purchase a new system, see your dealer to have them properly calibrated. Proper tire pressure is critical to safe operation of the vehicle.

OPERATION

19) Because it has been modified, the vehicle will not handle, turn, accelerate or stop in the same manner as an unmodified vehicle. In addition, the crash protection systems designed in the vehicle may operate differently from an unmodified vehicle. For example, turning and evasive maneuvers must be executed at a slower rate of speed. Further, there is a greater risk that the vehicle could roll over. These differences could result in an increased possibility of an accident, personal injury or death. Learn the vehicle's operations and handling characterizes and drive accordantly.

IMPORTANT NOTES

- A. Before installing this system, have the vehicle's alignment and frame checked by a certified technician. The alignment must be within factory specifications and the frame of the vehicle must be sound (no cracks, damage or corrosion). Have all suspension, steering and driveline components inspected and replaced if worn or damaged
- B. The components of Rancho's suspension system are designed as a single integrated system. To avoid compromises in terms of safety, performance, durability or function, do not install a body lift kit with Rancho's suspension system or interchange parts from this system with components from another manufacturer. Use of other components will result in the forfeiture of any type of warranty on the vehicle/suspension system.
- C. Some components required for the installation of this kit may need to be purchased separately. See "SPECIFICATIONS & REQUIREMENTS" on next page of this manual.
- D. Compare the contents of this system with the parts list in these instructions. If any parts are missing, contact the Rancho Technical Department at 1-734-384-7804.
- E. Do not powder-coat or plate any of the components in this system. To change the appearance of components, automotive paint can be applied over the original coating.
- F. Each hardware kit in this system contains fasteners of high strength and specific size. Do not mix hardware kits or substitute a fastener of lesser strength. See bolt identification table at end of instruction.
- G. Install all nuts and bolts with a flat washer. When both SAE (small OD) and USS (large OD) washers are used in a fastener assembly, place the USS washer against the slotted hole and the SAE washer against the round hole.
- H. Apply a drop of thread locking compound to all bolts during installation. ⚠ CAUTION: Thread locking compound may irritate sensitive skin. Read warning label on container before use.
- I. Unless otherwise specified, tighten all nuts and bolts to the standard torque specifications shown in the table at end of instruction. USE A TORQUE WRENCH for accurate measurements.
- J. Do not weld anything to these components, and do not weld any of these components to the vehicle unless specifically stated in the instructions
- K. It is extremely important to replace coil springs, axle flanges, and drive shaft/pinion relationships as original. Be sure to mark left/right, front/rear, and indexing of mating parts before disassembly. A paint marker or light colored nail polish is handy for this.
- L. Suspension components that use rubber or urethane bushings should be tightened with the vehicle at normal ride height unless otherwise specified. This will prevent premature failure of the bushing and maintain ride comfort.
- M. Some of the service procedures require the use of special tools designed for specific procedures. If you do not know how to safely use any of these tools, or do not have them, stop the project and consult a qualified mechanic. See "Tools and Supplies" on next page of this manual
- N. The required installation time for this system is approximately 8 hours for two people. Check off the box (☐) at the beginning of each step when you finish it. Then when you stop during the installation, it will be easier to find where you need to continue from.
- O. Important information for the end user is contained in the consumer/installer information pack. If you are installing this system for someone else, place the information pack on the driver's seat. Please include the installation instructions when you finish.
- P. The lifespan of Rancho products depends on many factors. Improper use, abuse or harsh use in general may compromise the integrity of the suspension system and significantly reduce its lifespan. The suspension system is also subject to wear over time. Have the suspension system regularly inspected and maintained by qualified mechanics. If the inspection reveals any damage or excessive wear, no matter how slight, immediately replace or repair the component. The suspension system must be regularly maintained in order to optimize its safe and efficient use. The more severe the conditions under which the suspension system is operated, the more often it must be inspected and maintained.
- Q. If any component breaks or bends, contact your local Rancho dealer or Rancho for replacement parts or, contact the Rancho Technical Department at 1-734-384-7804.

Thank you for purchasing the best suspension system available. For the best installed system, follow these instructions. If you do not have the tools or are unsure of your abilities, have this system installed by a certified technician. RANCHO IS NOT RESPONSIBLE FOR DAMAGE OR FAILURE RESULTING FROM AN IMPROPER INSTALLATION

The driver of this suspension system recognizes and agrees that there are risks inherent in driving a vehicle with a lifted suspension system, including but not limited to the risk that you could be involved in an accident that would not occur in an unmodified vehicle. By his/her purchase and use of this suspension system, the user expressly, voluntarily and knowingly accepts and assumes these risks, and agrees to hold Tenneco, Inc. and its related companies harmless to the fullest extent permitted by law against any resulting damages.

SPECIFICATIONS & REQUIREMENTS

Shock Absorbers

New front Rancho shock absorbers must be used with this kit.

RS999904 front shock absorbers are included.

New Ranch rear shock absorbers are recommended and can be purchased separately

Do not reuse OE front shock absorbers.

⚠️WARNING Use of the wrong shock absorbers can cause damage to vehicle without the damage being visible to you, resulting in loss of vehicle control and an accident

Required Rancho shock absorbers

Front	Rear
RS999044	RS999044
RS7044	RS7044
RS55044	RS55044
RS5044	RS5044
	OE

Wheels and Tires

This suspension system was developed using the following tire & wheel combination:

Tire: BF Goodrich® All-Terrain T/A® KO2 35X12.50R17

Wheel: 17" X 9" wheel with 5.5" of backspacing.

Total backspacing 6.8"

Maximum total backspacing is 6.8". Before installing any other combination, consult your local tire and wheel specialist.

Compatible With OE Wheels	Development Tire Size (Actual)	Wheel Size (Backspacing)
Yes ¹ 17" wheel and up only	35X12.50R17	17X9 (5.5")

¹ OE wheels and spare compatible with stock size tires only.

² Fitment of the optional tire size may require trimming to provide proper clearance.

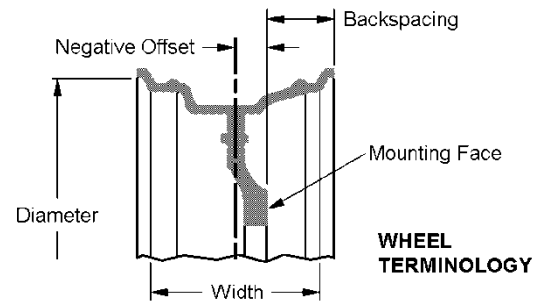

Tools and Supplies (BECAUSE OF VEHICLE VARIATIONS, THIS MAY NOT BE A COMPLETE LIST)

Dodge Ram Service Manual
Heavy Duty Jack Stands
Wheel Chocks (wooden blocks)
Hydraulic Floor Jack
Drill motor

Assorted Drills: 1/8" through 1/2"
Torque Wrench (250 FT-LB capacity)
1/2" Drive Ratchet and Sockets
Assorted Combination Wrenches
Hammer

Wire Brush (to clean bracket mounting surfaces)
Silicone Spray Lubricant
Tape Measure
Safety Glasses--
Wear safety glasses at all times



PARTS LIST

ITEM	PART #	DESCRIPTION	QTY
1	RS176830B	Coil Spacer - 2.25"	2
2	RS860826	Sub Assy - Right Coil Spacer	1
	RS176831B	Nut Plate - 7/16-14	1
	RS7718	HHCS, 7/16-14 X 4.00	1
	RS7726	Washer, 7/16 SAE	1
	RS770032	HHCS, 3/8-16 X 1.25	1
	RS7604	Nut, 3/8-16 Nylock	1
3	RS603508	Washer, 3/8 SAE	2
	RS860827	Sub Assy - Left Coil Spacer	1
3	RS176832B	Nut Plate - 1/4-20	1
	RS770178	HHCS 1/4-20X1.125	1
	RS77841	Washer 1/4 SAE	1
	RS770032	HHCS, 3/8-16 X 1.25	1
	RS7604	Nut, 3/8-16 Nylock	1
	RS603508	Washer, 3/8 SAE	2

ITEM	PART #	DESCRIPTION	QTY
4	RS176729B	Sway Bar Spacer, Left	1
5	RS176730B	Sway Bar Spacer, Right	1
	RS860753	Sub Assy, Sway Bar Spacer	1
	RS770080	HHCS, M10-1.50X30	4
	RS770259	Nut, M10-1.5 Nylock	4
6	RS770064	Washer, M10	8
	RS999044	Rancho RS9000XI Shock	2
	RS89454	Instructions	1
	RS94180	Information Pack	1
	RS94177	Rollover Warning	1
	RS94119	Consumer/Warranty Information	1
	RS780281	Rancho Decal	1
	R-RM0082-1112	Warranty Tag	1

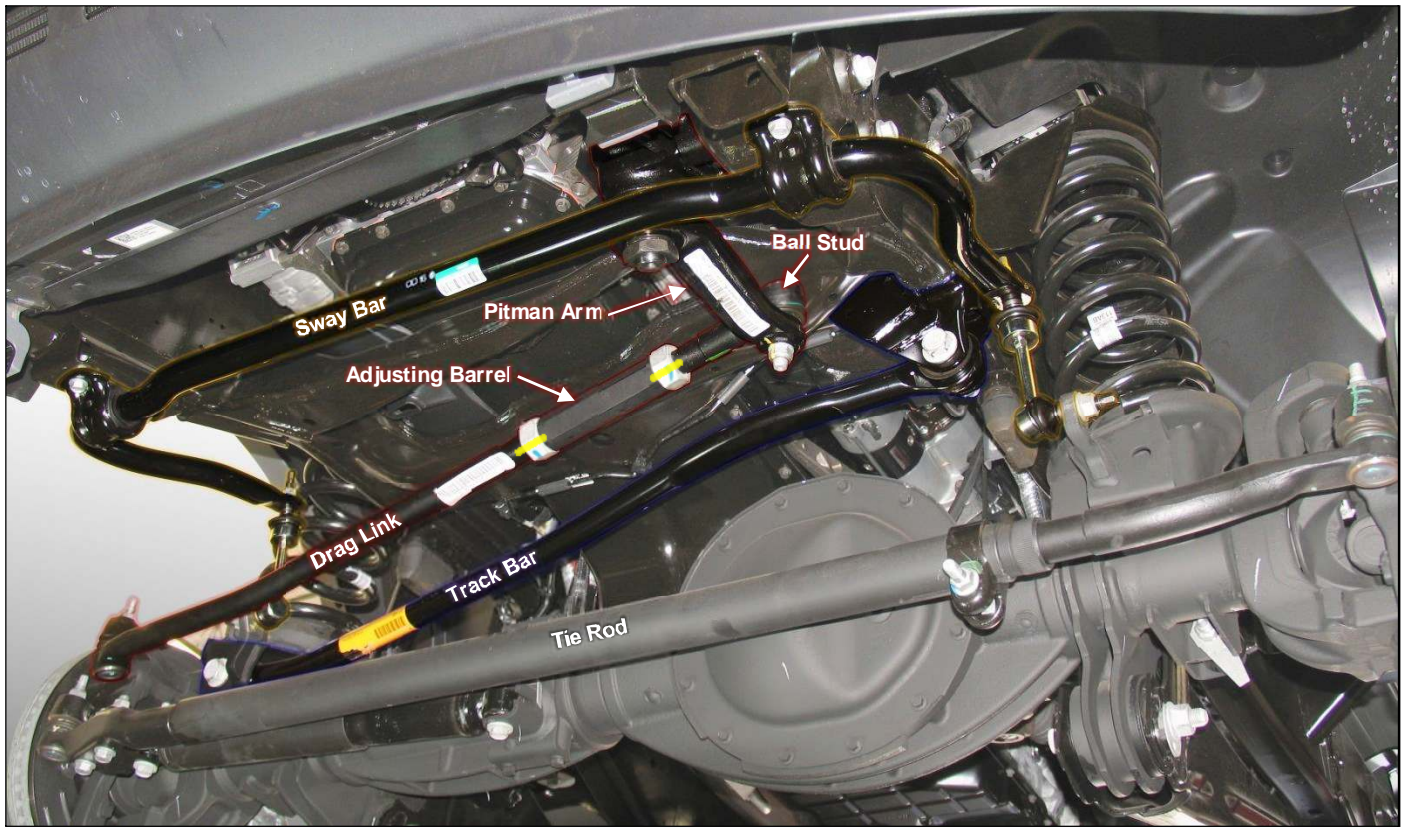

Illustration 1

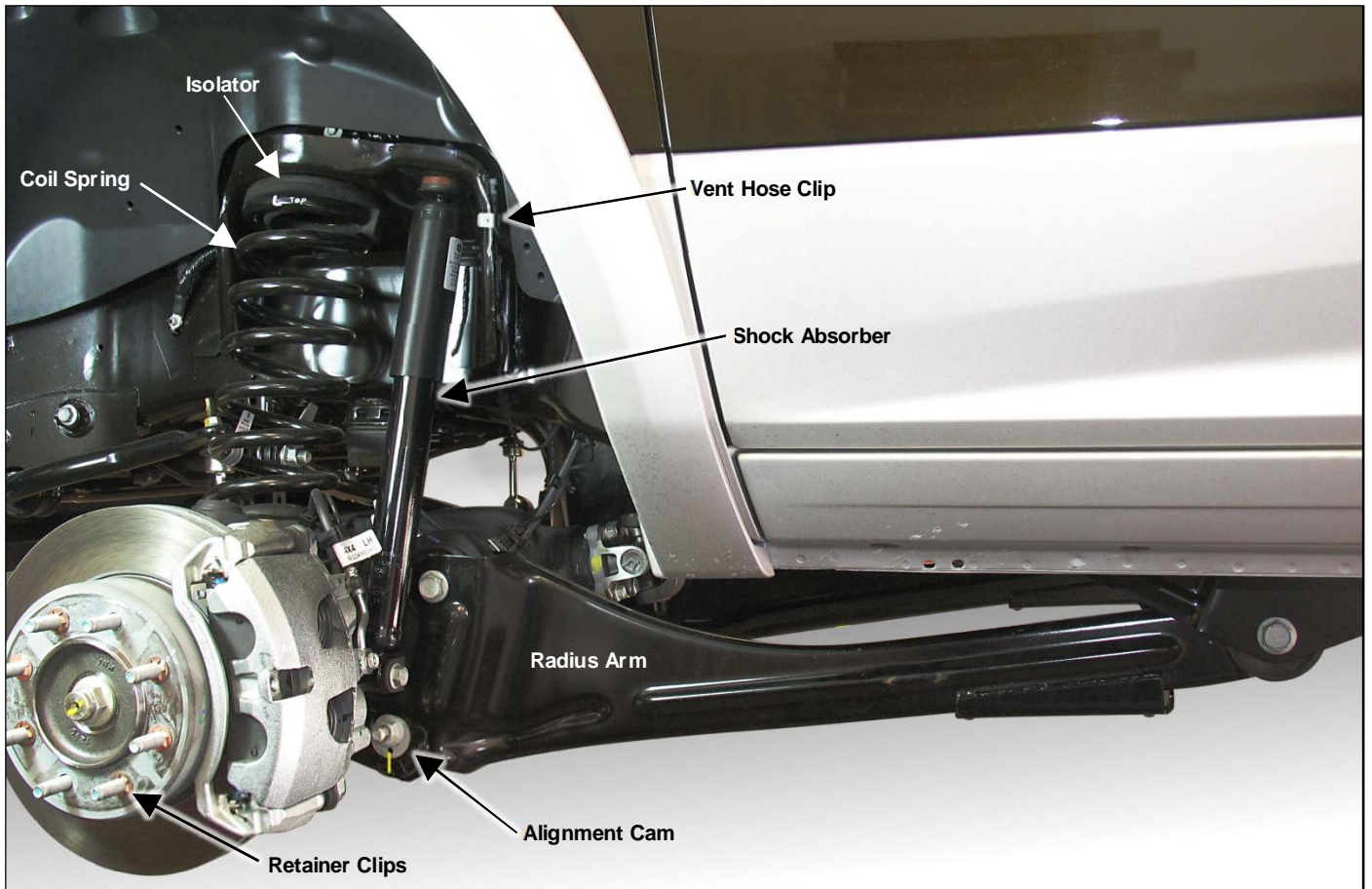

Illustration 2

VEHICLE PREPARATION & SWAY BAR REMOVAL

1) Park the vehicle on a level surface. Set the parking brake and chock the rear wheels. Measure and record the distance from the center of each wheel to the top of the fender opening. See Illustration 3. **Record these measurements in the space provided below.**

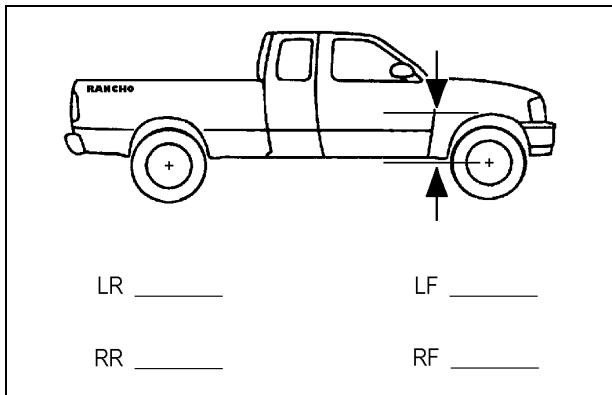

Illustration 3

2) Raise the front of the vehicle and support the frame with jack stands. Remove the front wheels and set them aside.

3) Remove the sway bar mounts at the frame. See Illustration 1.

4) Support the front axle with two floor jacks, one under each coil spring.

5) Mark position of alignment cam bolts on radius arms. See Illustration 2.

6) Loosen, but DO NOT REMOVE, radius arm to axle mounting bolts

7) Remove the mounting bolts holding the front brake hoses brackets to axle. There are 2 brackets on each side. See Illustration 4.

8) Remove clip attaching wire to solenoid on passenger side of axle. See Illustration 5.

9) Remove the front shock absorbers starting at the axle.

10) Carefully lower the axle enough to relieve the tension on the coil springs and remove coils and upper isolators.

⚠ WARNING: Do not allow the axle to hang by any hoses or ABS cables. You could damage the hoses or ABS cables, without this damage being visible to you, resulting in sudden and unexpected failure of a hose or ABS system, and an accident.

11) Disconnect the front differential vent hose clip at driver side shock/spring mount tower, and plastic clip on inside of frame rail. See Illustration 2 and Illustration 6.

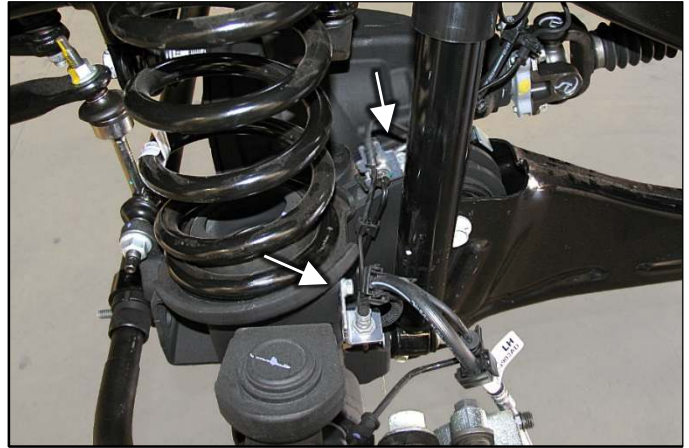

Illustration 4

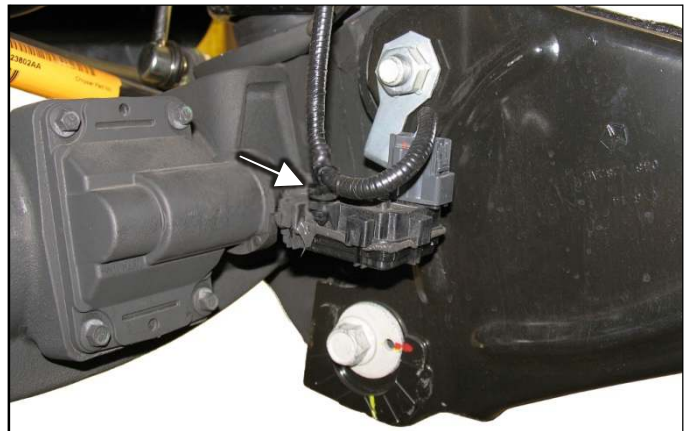

Illustration 5



Illustration 6

COIL SPRING SPACER & SHOCK ABSORBER INSTALLATION

1) Attach coil spacer RS176830B to driver side upper coil mount using hardware from sub assembly RS860827. Use 3/8" hardware through larger hole of spacer and upper coil mount.

Use 1/4" hardware and nut plate RS176832B through smaller holes. See Illustration 7.

Torque 3/8" hardware to 35 ft. lbs., and 1/4" hardware to 8 ft lbs.

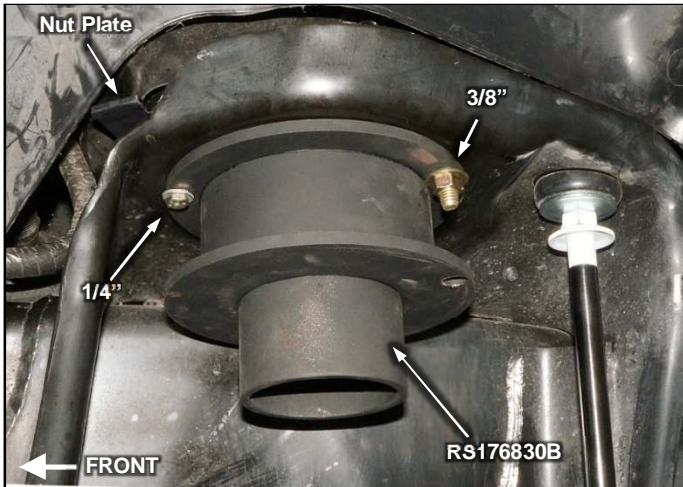

Illustration 7

2) Attach coil spacer RS176830B to passenger side upper coil mount using hardware from sub assembly RS860826.

Use 3/8" hardware through larger hole of spacer and upper coil mount.

Use 7/16" hardware in center hole of coil spacer and nut plate RS176831B on top of upper mount inside engine compartment. See Illustration 8.

Torque hardware to 35 ft. lbs. starting with 7/16 bolt.

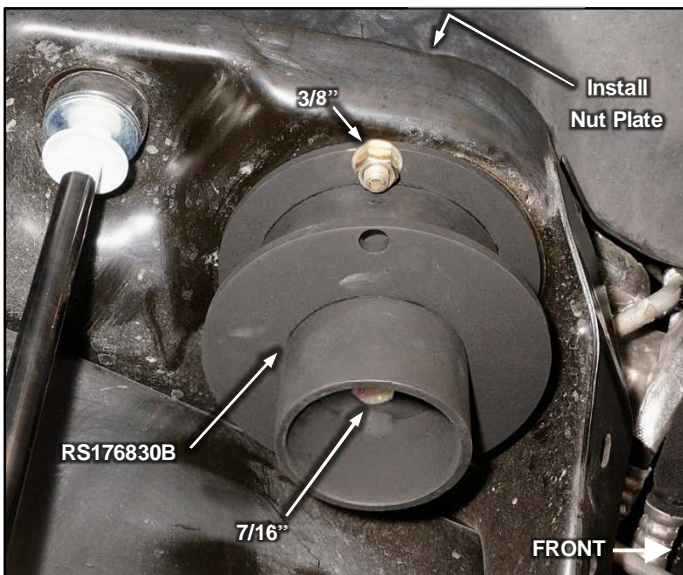

Illustration 8

3) Re-install coils and upper isolators. Slowly raise axle to seat coils and isolators. The locating tab of the isolators fit into the hole in the coil mount. See Illustration 9.

4) Install new Rancho shocks in the upper shock mounts.

5) Carefully raise the axle enough to install the shocks on the lower mounts. Attach with the OE hardware and torque to 120 ft. lbs.



Illustration 9

6) Re-attach all OE brake line brackets to axle. Re-shape brake line enough to take tension off of rubber line by pushing up on the bend of the hard line. See Illustration 10.

NOTE: Use loctite and take care not to strip out self-tapping screws used on brake line mounts.



Illustration 10

7) Re-attach axle vent hose clips at OE locations. See Illustration 2 and Illustration 6.

SWAY BAR DROP BRACKET INSTALLATION

1) Attach left sway bar drop bracket RS176729B to the driver side the frame with OE hardware. The Rancho logo will face out, and the sway bar will be offset to the front of the vehicle. See Illustration 11.

3) Attach right sway bar drop bracket RS176730B to the passenger side the frame with OE hardware. The Rancho logo will face out, and the sway bar will be offset to the front of the vehicle. See Illustration 11.



Illustration 11

4) Attach the sway bar to the drop brackets with 10mm hardware from kit RS860753. Torque hardware to 40 ft. lbs.

LOWER VEHICLE

1) Install the front wheels and lower the vehicle to the ground. Tighten lug nuts to 165 ft. lbs.

Note: If installing aftermarket wheels, remove rotor retainer clips from wheel studs to allow wheels to sit flush against rotor.

2) Adjust cam bolts so lobe of cam points to rear of vehicle (about 1/4" turn from OE). Tighten radius arm bolts at axle to 220 ft. lbs. See Illustration 12.



Illustration 12

FINAL CHECKS & ADJUSTMENTS

1) Turn the front wheels completely left then right. Verify adequate tire, wheel, and brake hose clearance. Inspect steering and suspension for tightness and proper operation.

2) With the suspension at maximum extension (full droop), inspect and rotate all axles and driveshafts. Check for binding and proper slip yoke insertion. The slip yoke should be inserted a minimum of one inch into the transfer case and/or transmission.

3) Ensure that the vehicle brake system operates correctly. If new brake hoses were installed, verify that each hose allows for full suspension movement.

4) Readjust headlamps. Have vehicle Aligned at a certified alignment facility.

Recommended Alignment Specifications

- Caster (degrees): 4.5° ± 1.0°
- Camber (degrees): 0°- neg .3°
- Sum Toe In (degrees): .1° ± .2°

5) Park the vehicle on a level surface. Set the parking brake and chock rear wheels. Measure and record the distance from the center of each wheel to the top of the fender opening. Record these measurements in the space provided below.

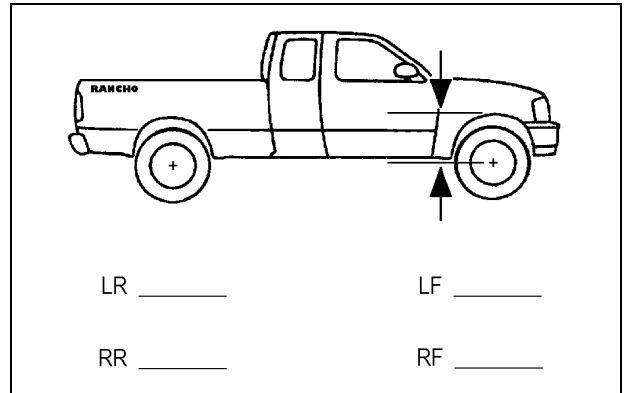

Please retain this publication for future reference.

STANDARD BOLT TORQUE & IDENTIFICATION

INCH SYSTEM			METRIC SYSTEM			
Bolt Size	Grade 5	Grade 8	Bolt Size	Class 8.8	Class 10.9	Class 12.9
5/16	15 LB-FT	20 LB-FT	M6	5 LB-FT	9 LB-FT	12 LB-FT
3/8	30 LB-FT	35 LB-FT	M8	18 LB-FT	23 LB-FT	27 LB-FT
7/16	45 LB-FT	60 LB-FT	M10	32 LB-FT	45 LB-FT	50 LB-FT
1/2	65 LB-FT	90 LB-FT	M12	55 LB-FT	75 LB-FT	90 LB-FT
9/16	95 LB-FT	130 LB-FT	M14	85 LB-FT	120 LB-FT	145 LB-FT
5/8	135 LB-FT	175 LB-FT	M16	130 LB-FT	165 LB-FT	210 LB-FT
3/4	185 LB-FT	280 LB-FT	M18	170 LB-FT	240 LB-FT	290 LB-FT

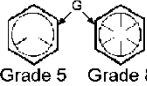
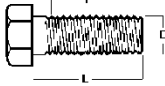
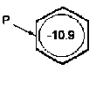
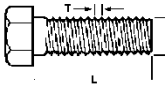
<p>1/2-13x1.75 HHCS</p> <p align="center"> D T L X </p> <p>G = Grade Marking (bolt strength) D = Nominal Diameter (inches) T = Thread Pitch (threads per inch)</p> <p align="center">  </p> <p>Grade 5 Grade 8</p> <p>L = Length (inches) X = Description (hex head cap screw)</p> <p align="center">  </p>	<p>M12-1.25x50 HHCS</p> <p align="center"> D T L X </p> <p>P = Property Class (bolt strength) D = Nominal Diameter (millimeters) T = Thread Pitch (thread width, mm)</p> <p align="center">  </p> <p>P</p> <p>L = Length (millimeters) X = Description (hex head cap screw)</p> <p align="center">  </p>
--	--



<http://www.gorrancho.com/>

Rancho Technical Department 1-734-384-7804.