



Rancho Suspension System — RS66119BR5 and RS66119BR9  
2" Progressive Sport System  
Fits 2018-2007 Jeep Wrangler JK 4-Door

This suspension system was developed using 255/80R17 tires. Before installing any other size tire, consult your local tire and wheel specialist. See page 4.



**⚠ WARNING**

Carefully read, understand and follow the instructions provided in this manual, and keep it in a safe place for future reference. If you have any doubt whatsoever regarding the installation or maintenance of your Rancho suspension system, please see your retailer for assistance or advice. Failure to follow the warnings and instructions provided herein can result in the failure of the suspension system, or can cause you to lose control of your vehicle, resulting in an accident, severe personal injury or death.

These instructions should remain in the vehicle glove box for future reference.

**⚠ WARNING: READ ALL INSTRUCTIONS THOROUGHLY FROM START TO FINISH BEFORE BEGINNING INSTALLATION. Failure to follow the warnings and instructions provided herein can result in an accident, severe personal injury or death.**

## **PRELIMINARY**

This manual presumes that all persons installing this suspension system have a high level of mechanical training and experience, and have available to them all necessary tools and safety equipment. This manual is not and should not be construed as an exhaustive list of all required safety measures. Personnel should rely primarily on their training and experience, as well as on their own common sense.

This Manual is to be read as a supplement to, and must not be construed as a substitute for, the owner's manual and/or shop manual that originally accompanied the vehicle. Refer to such use, operation, maintenance and safety manuals as necessary, and especially after installation is complete, to insure proper vehicle operation.

The following terminology has been used in this Manual:

**ACCIDENT:** Any event which could cause personal injury or death to anyone installing or using the suspension system, as well as to passengers and bystanders, or otherwise may result in property damage.

## **PRE-INSTALLATION WARNINGS and INSTRUCTIONS**

**⚠ WARNING: Only the following wheel / tire size may be used with this suspension system: 255/80R17 tires, 17" x 9" wheel with 4.5" of backspacing.**

**Use of any other rim/tire combination increases the risk of a roll-over and/or accident, resulting in severe personal injury or death.**

**⚠ WARNING: This suspension system will enhance the off-road performance of your vehicle. It will handle differently; both on and off-road, from a factory equipped passenger car or truck. Failure to drive this vehicle safely may result in serious injury or death to the driver and passengers. ALWAYS WEAR your seat belts, REDUCE your speed, and AVOID sharp turns and other abrupt maneuvers.**

1) Service and repair tasks require specialized knowledge, training, tools, and experience. General mechanical aptitude may not be sufficient to properly install this suspension system. If you have any doubt whatsoever regarding your ability to properly install the suspension system, please consult a qualified mechanic.

2) Your brake lines and fuel lines should remain undisturbed during and after installation. If you think you need to modify these components in any way, you are mistaken. You are installing the lift improperly and will be creating a significant risk of an accident. In case of any doubt, consult a qualified mechanic.

3) If any component does not fit properly, something is wrong. You are installing the lift kit improperly and will be creating a significant risk of an accident. Never modify any component of the vehicle or suspension system, except as instructed herein. Do not continue with installation until you have identified the problem.

4) Several of the procedures described herein require at least two (2) persons to safely complete the task. If you have any doubt about your ability to complete any operation by yourself, always ask for help from a qualified assistant.

5) Before starting any operation, confirm that all personal safety devices and safety equipment are in proper condition and position.

6) Give your work undivided attention. Looking around, carrying on a conversation and "horse-play" are careless acts that can result in an error in installation and/or serious injury.

7) Install only tires approved by the United States Department of Transportation ("DOT approved"). Make sure the rim and tire size are properly matched.

8) If any components of the vehicle or suspension system are damaged in any way during installation, immediately replace the component.

9) During installation, carefully inspect all parts of the vehicle and replace anything that is worn or damaged.

10) Nip points present the risk of the catching, lacerating, crushing and/or amputating fingers, hands, limbs and other body parts during operations. Always keep clear. Wear protective gloves.

11) Oil and hydraulic fluids are poisonous, dangerous to health and are known to the State of California to cause cancer, birth defects or other reproductive harm. Do not inhale vapors or swallow. Do not allow contact with the eyes or skin. Should any oil or fluids be swallowed or inhaled or come into contact with the eyes, immediately follow the safety precautions on the label or call a poison control center immediately. Should any of the oil or fluids contact your skin, immediately wash thoroughly.

12) Never install the suspension system if you are under the effects of alcohol, medications and/or drugs. If you are taking prescription or over the counter medication, you must consult a medical professional regarding any side effects of the medication that could hinder your ability to work safely.

## **AFTER INSTALLATION WARNINGS AND INSTRUCTIONS**

13) After installation is complete, drive the vehicle slowly in an area free from heavy traffic for at least three (3) miles. Likewise, before traveling on any highways or at a high rate of speed, drive the vehicle for ten (10) miles on side roads at moderate speed. If you hear any strange noise or feel unusual vibration, if a component of the suspension system is not operating properly, or if any warning lights illuminate or buzzers sound, stop the vehicle immediately. Identify the cause and take any necessary remedial action.

14) Confirm that all components of the vehicle, including all lights (headlights, turn signals, brake lights, etc.), linkages (accelerator, etc.), electrical switches and controls (windshield wipers and defoggers, etc.), and other warning devices (low tire pressure monitoring systems) are fully operational.

15) Your headlights will need to be readjusted before the vehicle is used on the roads. Consult the vehicle owners' manual.

16) The speedometer and odometer will need to be recalibrated after installation. See your dealer.

17) Confirm proper rear view and side view while seated in the driver seat. Install supplemental mirrors as necessary.

18) Your original low tire pressure monitoring system may be re-installed in your new wheels. However, if you choose to purchase a new system, see your dealer to have them properly calibrated. Proper tire pressure is critical to safe operation of the vehicle.

## **OPERATION**

19) Because it has been modified, the vehicle will not handle, turn, accelerate or stop in the same manner as an unmodified vehicle. In addition, the crash protection systems designed in the vehicle may operate differently from an unmodified vehicle. For example, turning and evasive maneuvers must be executed at a slower rate of speed. Further, there is a greater risk that the vehicle could roll over. These differences could result in an increased possibility of an accident, personal injury or death. Learn the vehicle's operations and handling characterizes and drive accordingly.

## IMPORTANT NOTES

- A. Before installing this system, have the vehicle's alignment and frame checked by a certified technician. The alignment must be within factory specifications and the frame of the vehicle must be sound (no cracks, damage or corrosion). Have all suspension, steering and driveline components inspected and replaced if worn or damaged
- B. The components of Rancho's suspension system are designed as a single integrated system. To avoid compromises in terms of safety, performance, durability or function, do not install a body lift kit with Rancho's suspension system or interchange parts from this system with components from another manufacturer. Use of other components will result in the forfeiture of any type of warranty on the vehicle/suspension system.
- C. Some components required for the installation of this kit may need to be purchased separately. See "SPECIFICATIONS & REQUIREMENTS" on next page of this manual.
- D. Compare the contents of this system with the parts list in these instructions. If any parts are missing, contact the Rancho Technical Department at 1-800-325--8886.
- E. Do not powder-coat or plate any of the components in this system. To change the appearance of components, automotive paint can be applied over the original coating.
- F. Each hardware kit in this system contains fasteners of high strength and specific size. Do not mix hardware kits or substitute a fastener of lesser strength. See bolt identification table at end of instruction.
- G. Install all nuts and bolts with a flat washer. When both SAE (small OD) and USS (large OD) washers are used in a fastener assembly, place the USS washer against the slotted hole and the SAE washer against the round hole.
- H. Apply a drop of thread locking compound to all bolts during installation. ⚠ CAUTION: Thread locking compound may irritate sensitive skin. Read warning label on container before use.
- I. Unless otherwise specified, tighten all nuts and bolts to the standard torque specifications shown in the table at end of instruction. USE A TORQUE WRENCH for accurate measurements.
- J. Do not weld anything to these components, and do not weld any of these components to the vehicle unless specifically stated in the instructions. Welding on a vehicle creates an electrical charge throughout the body and frame. Disconnect the vehicle's battery prior to any welding. Place welding ground clamps as near as possible to the weld. Never use a vehicle suspension component as a welding ground point.
- K. It is extremely important to replace coil springs, axle flanges, and drive shaft/pinion relationships as original. Be sure to mark left/right, front/rear, and indexing of mating parts before disassembly. A paint marker or light colored nail polish is handy for this.
- L. Suspension components that use rubber or urethane bushings should be tightened with the vehicle at normal ride height unless otherwise specified. This will prevent premature failure of the bushing and maintain ride comfort.
- M. Some of the service procedures require the use of special tools designed for specific procedures. If you do not know how to safely use any of these tools, or do not have them, stop the project and consult a qualified mechanic. See "Tools and Supplies" on next page of this manual
- N. The required installation time for this system is approximately 4 to 5 hours for two people. Check off the box (☐) at the beginning of each step when you finish it. Then when you stop during the installation, it will be easier to find where you need to continue from.
- O. Important information for the end user is contained in the consumer/installer information pack. If you are installing this system for someone else, place the information pack on the driver's seat. Please include the installation instructions when you finish.
- P. The lifespan of Rancho products depends on many factors. Improper use, abuse or harsh use in general may compromise the integrity of the suspension system and significantly reduce its lifespan. The suspension system is also subject to wear over time. Have the suspension system regularly inspected and maintained by qualified mechanics. If the inspection reveals any damage or excessive wear, no matter how slight, immediately replace or repair the component. The suspension system must be regularly maintained in order to optimize its safe and efficient use. The more severe the conditions under which the suspension system is operated, the more often it must be inspected and maintained.
- Q. If any component breaks or bends, contact your local Rancho dealer or Rancho for replacement parts or, contact the Rancho Technical Department at 1-1-800-325--8886.

Thank you for purchasing the best suspension system available. For the best installed system, follow these instructions. If you do not have the tools or are unsure of your abilities, have this system installed by a certified technician. RANCHO IS NOT RESPONSIBLE FOR DAMAGE OR FAILURE RESULTING FROM AN IMPROPER INSTALLATION

**The driver of this suspension system recognizes and agrees that there are risks inherent in driving a vehicle with a lifted suspension system, including but not limited to the risk that you could be involved in an accident that would not occur in an unmodified vehicle. By his/her purchase and use of this suspension system, the user expressly, voluntarily and knowingly accepts and assumes these risks, and agrees to hold DRiV, Inc. and its related companies harmless to the fullest extent permitted by law against any resulting damages.**

## SPECIFICATIONS & REQUIREMENTS

### **Shock Absorbers**

New Rancho shock absorbers must be used with this kit, and must be purchased separately

Do not reuse OE shock absorbers

**⚠️WARNING** Use of the wrong shock absorbers can cause damage to vehicle without the damage being visible to you, resulting in loss of vehicle control and an accident

#### **Required Rancho shock absorbers**

Front	Rear
RS999326	RS999330
RS55326	RS55330
RS5326	RS5330

### **Wheels and Tires**

This suspension system was developed using the following tire & wheel combination:

Tire: BF Goodrich® Mud-Terrain™ T/A® KM-255/80R17

Wheel: 17" x 9" wheel with 4.5" of backspacing.

Total backspacing 5.9"

Before installing any other combination, consult your local tire and wheel specialist.

Compatible With OE Wheels	Development Tire Size (Actual)	Optional Tire Size (Actual)	Wheel Size (Backspacing)
Yes <sup>1</sup>	255/80R17 (33.3"x10.0")	285/75R17 <sup>2</sup> (33.9"x11.3")	17x9 (4.5")

<sup>1</sup> OE wheels compatible with stock size tires only.

<sup>2</sup> Optional tire size may require some trimming (body pinch seam at the front edge of the rear fender well).

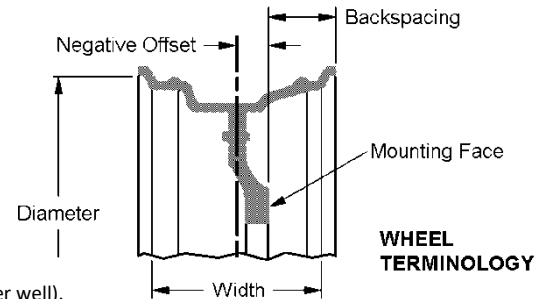

### **Recommended Components and Modifications** (MUST BE PURCHASED SEPARATELY)

If you have a winch mounted to the front bumper, use 3/4" spring spacer RS70082 to compensate for the additional weight.

### **Tools and Supplies** (BECAUSE OF VEHICLE VARIATIONS, THIS MAY NOT BE A COMPLETE LIST)

Jeep Service Manual  
Torque Wrench (150 FT-LB capacity)  
Hammer  
1/2" Drive Ratchet and Sockets  
Combination Wrenches

3/8-16 Tap  
Wire Brush (to clean mounting surfaces)  
Red and Blue Loctite  
Penetrating Lube (to aid removal of corroded and frozen hardware)

File  
Hydraulic Floor Jack  
Heavy Duty Jack stands  
Wheel Chocks (Wooden Blocks)  
**Safety Glasses-**  
Wear safety glasses at all times



### Parts List

PART #	DESCRIPTION	QTY
RS860B	Front Coil, 2" Progressive	2
RS861B	Rear Coil, 2" Progressive	2
RS176443	Front Bumpstop	2
RS860710	Sub Assy. Front Bumpstop	1
RS7713	HHTS, 3/8-16 X 1.5	2
RS860711	Sub Assy. Rear Bracket	1
RS176442	Rear Brakeline Bracket	2
RS603615	HHCS, 1/4-20 X .75	2
RS7907	Nut, 1/4-20 Stover	2
RS77841	Washer 1/4 SAE	4
RS94180	Information Pack	1
RS89119	Instructions	1
RS94177	Rollover Warning L	1
RS94119	Warning, Oper & In	1
RS780281	6" Rancho Decal -	1
R-RM0082-1112	Warranty Tag	1

Included With RS66119BR5 ONLY		
RS55326	RS5000X Shock (Front)	2
RS55330	RS5000X Shock (Rear)	2
Included With RS66119BR9 ONLY		
RS999326	RS9000XL Shock (Front)	2
RS999330	RS9000XL Shock (Rear)	2

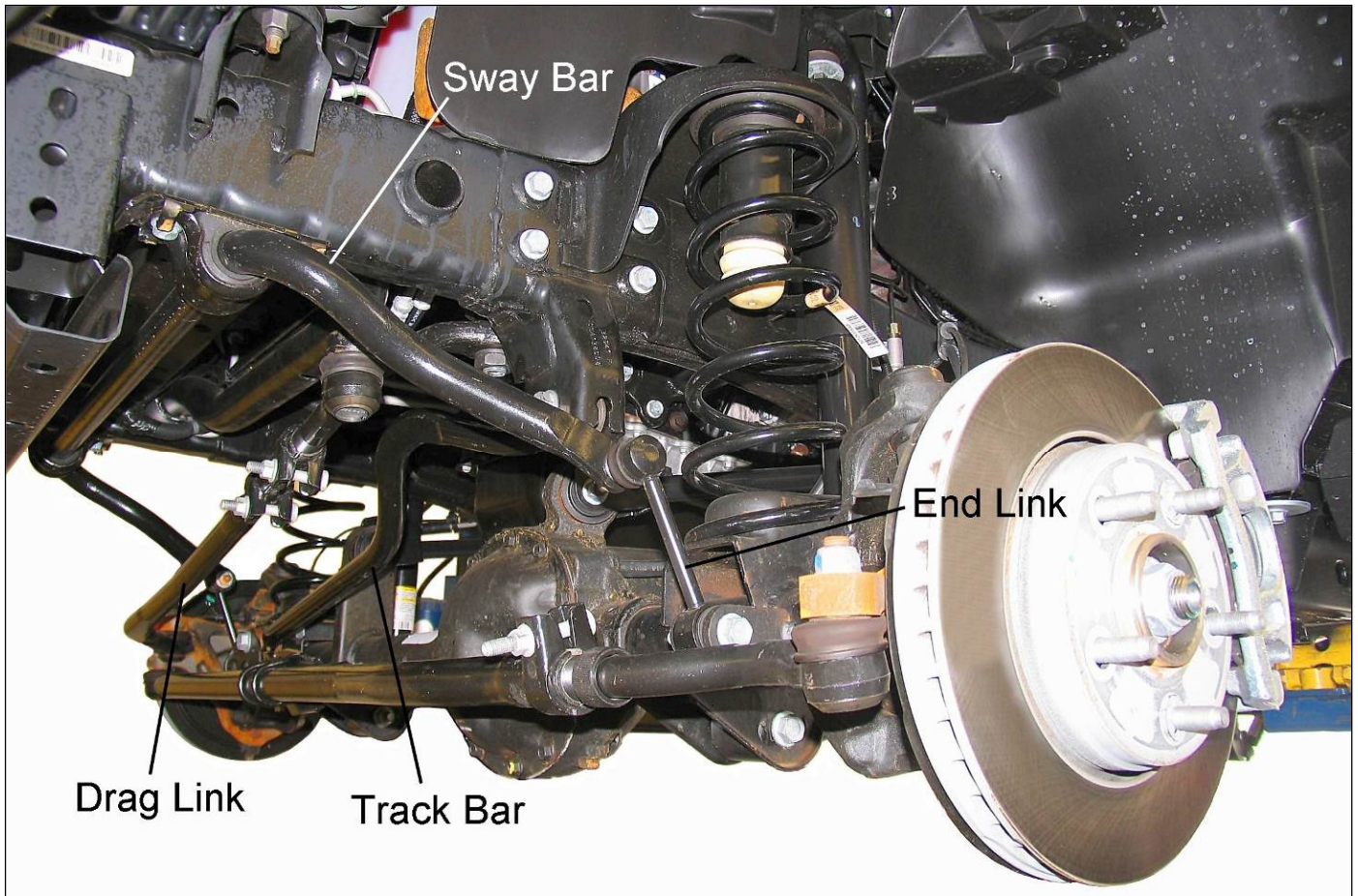
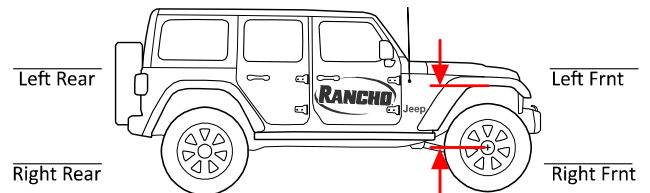

Illustration 1

**FRONT SUSPENSION**

**SHOCK ABSORBER & COIL SPRING REMOVAL**

- 1)  Park vehicle on a level surface. Set the parking brake and chock rear wheels. Disconnect the negative ground cable from the battery.
- 2)  Measure and record the distance from the center of each wheel to the top of the fender opening. Record these measurements in the space provided.



4 Door OE Measured Static Height – Soft Top

Front	
20.2"	20.2"
-----	
21.5"	21.5"
Rear	

RS66119BR5/9 Measured Static Height – Soft Top

Front	
22.5"	22.5"
-----	
22.3"	22.3"
Rear	

- 3)  Remove the track bar to frame bracket nut and bolt.
- 4)  Raise the front of the vehicle and support the frame with jack stands. Remove the front wheels and set them aside.
- 5)  Support the front axle with a floor jack.
- 6)  Disconnect the sway bar end links from the axle.
- 7)  Reference mark the drive shaft to the front differential. Disconnect the drive shaft from the differential. Support drive shaft with a tie wrap or wire.
- 8)  Remove the shock absorber upper nut, retainer, and bushing.
- 9)  Remove the shock absorber lower nut and bolt. Remove the front shock absorber.
- 10)  Repeat steps 8 and 9 for the other side.

DO NOT REUSE ORIGINAL SHOCK ABSORBERS.

- 11)  Remove bolts and separate the brake hoses from the frame rails. If necessary, disconnect any vent hoses and electrical wiring from the axle.
- 12)  Carefully lower the front axle and remove the coil springs. Push down on axle if necessary.

**CAUTION:** Do not allow the front axle to hang by any hoses or cables.

#### **BUMP STOP SPACER, COIL SPRING & SHOCK ABSORBER INSTALLATION**

- 1)  Drill a 5/16" hole through the center of the coil spring axle pad. For ease of installation, tap the hole (3/8-16).
- 2)  Install original rubber isolator on top of coil spring 860B. Place bump stop spacer RS176443 inside the coil spring.
- 3)  Lower axle if required and insert the spring assembly into the upper pocket and onto the axle pad. Align pig tail with groove in axle pad. See Illustration 2

**CAUTION:** Do not allow the front axle to hang by any hoses or cables.

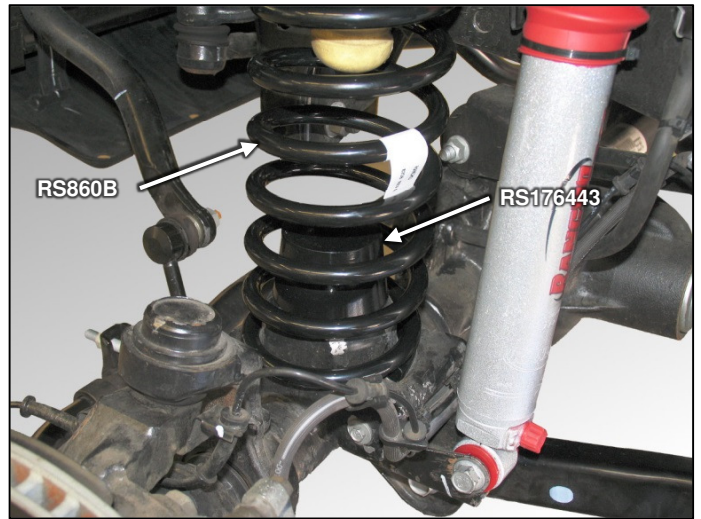

Illustration 2

- 4)  Attach the bump stop spacer to the axle pad with the self-tapping screw from kit RS860710 and red Loctite. Torque to 20 lb-ft.
- 5)  Repeat steps 2 through 5 for the other side.
- 6)  Install retaining washer and bushing on NEW shock absorber, insert shock into upper mounting hole. Install bushing, washer and nut. Tighten nut until bushing swells larger than retaining wash (about 17 lb-ft). Repeat for other side.
- 7)  Raise front axle and attach shock lower mounts to axle brackets with the original hardware. Torque to 56 lb-ft.
- 8)  Reattach the sway bar end links to the axle. Torque to 75 lb-ft.
- 9)  Reattach drive shaft to pinion flange using OE hardware and blue Loctite. Torque to 81 lb-ft.
- 10)  Reattach vent hose and electrical wiring if necessary.

#### **LOWER VEHICLE**

- 1)  Install front wheels and lower vehicle to the ground. Tighten lug nuts to 80-110 lb-ft.
- 2)  Attach track bar to frame mount using OE hardware
- 3)  Torque upper and lower track bar bolts to 125 lb-ft. Torque Jam nut to 150 lb-ft.

Note: If track bar does not align with bracket, have an assistant slowly turn steering wheel to align holes.

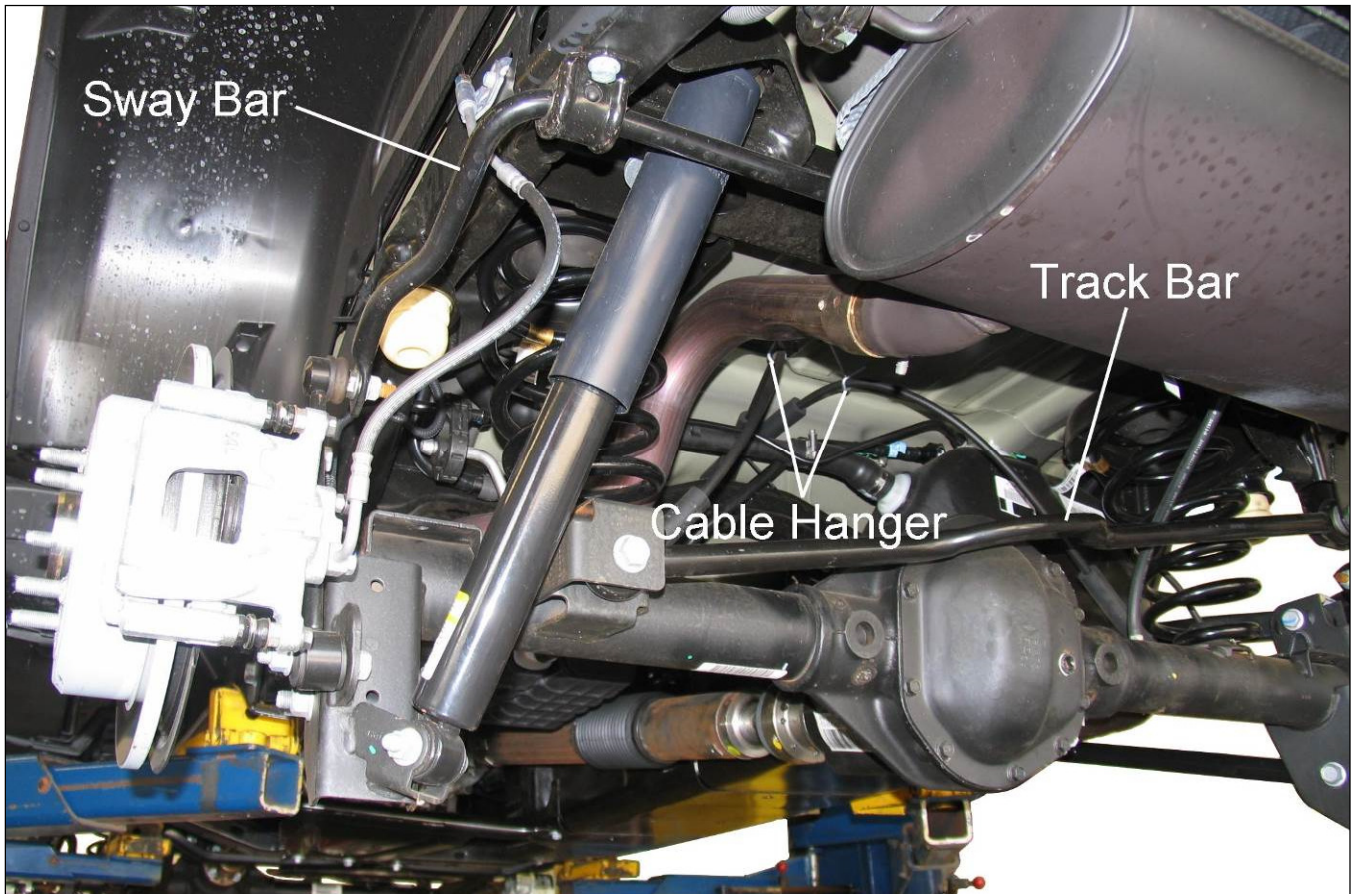

Illustration 3

## REAR SUSPENSION

### SHOCK ABSORBER & COIL SPRING REMOVAL

- 1)  Disconnect the track bar from the frame bracket.
- 2)  Disconnect the sway bar end links from the axle.
- 3)  Chock front wheels. Raise the rear of the vehicle and support the frame with jack stands. Remove the rear wheels.
- 4)  Support the rear axle with a floor jack.
- 5)  Remove bolts and separate the brake hoses from the frame rails. Remove clips holding ABS wire to frame. If necessary, disconnect any vent hoses and electrical wiring from the axle.
- 6)  Remove the nuts or bolts from the brake parking cable hanger above the rear axle. Remove the hanger from the cables. Hanger will not be re-used.
- 7)  Remove the shock absorber upper mounting bolts. Remove the lower nut and bolt from the axle bracket. Remove the shock absorber. Repeat for other side.
- 8)  Carefully lower the rear axle until the coil springs are free from the upper mount seat. Remove the coil springs.

**CAUTION:** Do not allow the axle to hang by any hoses or cables.

### COIL SPRING & SHOCK ABSORBER INSTALLATION

- 1)  Place OE isolators on top of new coil springs RS861B.
- 2)  Set coil onto the axle pads. Raise the axle until the coil springs and isolators seat on the upper mounts. Move coils back and forth to seat on upper mounts when raising axle. Align the last wrap of the coil so it hooks around the front of the upper mount. See Illustration 4.

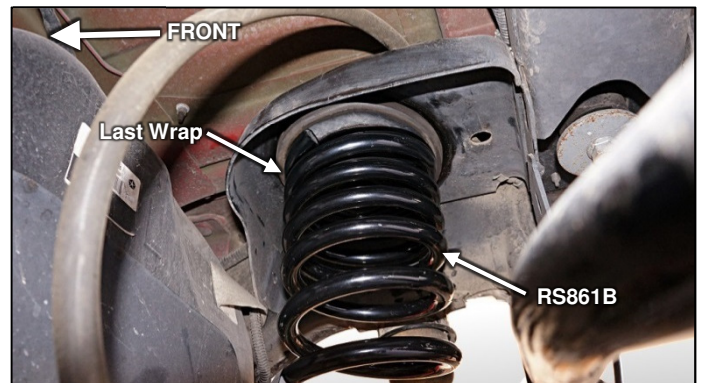

Illustration 4

**NOTE:** When installing coil springs, make sure that the rubber isolator is positioned in the upper mount and the small egg-shaped pig tail end is at the bottom.



- 3)  Attach new Rancho rear shocks to the upper mounting brackets with the original bolts. Tighten bolts to 23 lb-ft.
- 4)  Attach shocks to the axle brackets with the original hardware. Torque the shock absorber lower mounting bolts to 74 lb-ft.

### **BRAKE LINE BRACKET INSTALLATION**

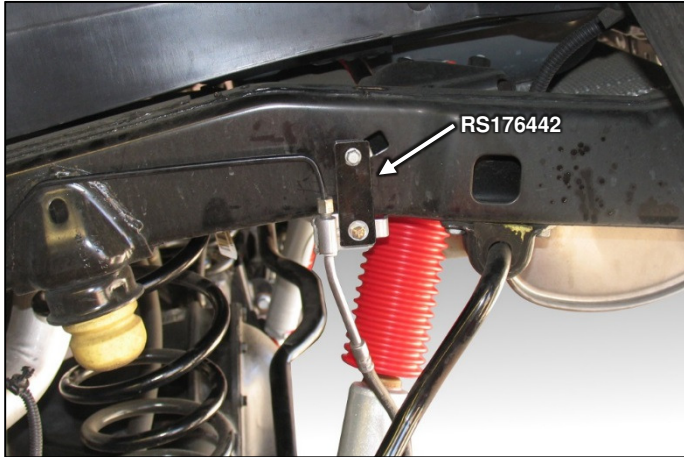

Illustration 5

- 1)  Attach brake line bracket RS176442 to the frame rail with the original brake line bolt. See Illustration 5.
- 2)  Attach brake line to the inside of bracket RS176442 with the 1/4" hardware from kit RS860575. Tighten nuts and bolts to 12 ft lbs.
- 3)  Repeat steps 1 through 2 for other side.
- 4)  Reattach end to links axle using OE hardware. Tighten to 75 lb-ft.
- 5)  Reattach the sway bar end links to the axle. Torque to 75 lb-ft.

### **LOWER VEHICLE**

- 1)  Install rear wheels and lower vehicle to the ground. Tighten lug nuts to 80-110 lb-ft.
- 2)  Attach rear track bar to frame bracket using OE hardware. Torque track bar hardware at frame and axle bracket to 125 lb-ft.
- 3)  Reconnect the battery ground cable.

## **FINAL CHECKS & ADJUSTMENTS**

- 1)  Turn the front wheels completely left then right. Verify adequate tire, wheel, brake hose and ABS wire clearance. Inspect steering and suspension for tightness and proper operation.
- 2)  With the suspension at maximum extension (full droop), inspect and rotate all axles and drive shafts. Check for binding and proper slip yoke insertion. The slip yoke should be inserted a minimum of one inch into the transfer case and/or transmission.
- 3)  Ensure that the vehicle brake system operates correctly. If new brake hoses were installed, verify that each hose allows for full suspension movement.
- 4)  Readjust headlamps.
- 5)  Have vehicle Aligned to manufacturer's specifications.

### Alignment Specifications

Caster	4.6°	± 1.0°
Camber (fixed angle)	-0.25°	± 0.63°
Toe-In (each wheel)	0.15°	± 0.15°
Thrust Angle	0	± 0.15°

- 6)  Park the vehicle on a level surface. Measure and record the distance from the center of each wheel to the top of the fender opening. Record these measurements in the space provided.

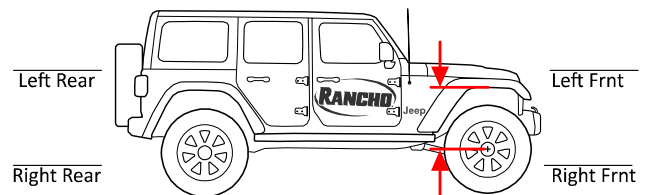

### Torque Specs

#### Front Components

Upper Control Arm	75 lb-ft
Lower Control Arm	125 lb-ft
Front Bump Stop Spacer RS176443	20 lb-ft
Shock Absorber Lower Mount	56 lb-ft
Front Drive Shaft to Pinion Flange	81 lb-ft
Sway Bar end Link	75 lb-ft
Track Bar	125 lb-ft
Drag Link Adjustment Sleeve Clamp	26 lb-ft
Wheels (Lug Nuts)	110 lb-ft.



#### Rear Components

Control Arm	125 lb-ft
Shock Absorber Upper Mount	23 lb-ft
Shock Absorber Lower Mount	56 lb-ft
Track Bar	125 lb-ft
Sway Bar to Frame	33 lb-ft
Brake Line Drop Bracket RS176442	12 lb-ft
Sway Bar End Link to Axle	75 lb-ft
Wheels (Lug Nuts)	110 lb-ft

### STANDARD BOLT TORQUE AND IDENTIFICATION

INCH SYSTEM			METRIC SYSTEM			
Bolt Size	Grade 5	Grade 8	Bolt Size	Class 8.8	Class 10.9	Class 12.9
5/16	15 LB-FT	20 LB-FT	M6	5 LB-FT	9 LB-FT	12 LB-FT
3/8	30 LB-FT	35 LB-FT	M8	18 LB-FT	23 LB-FT	27 LB-FT
7/16	45 LB-FT	60 LB-FT	M10	32 LB-FT	45 LB-FT	50 LB-FT
1/2	65 LB-FT	90 LB-FT	M12	55 LB-FT	75 LB-FT	90 LB-FT
9/16	95 LB-FT	130 LB-FT	M14	85 LB-FT	120 LB-FT	145 LB-FT
5/8	135 LB-FT	175 LB-FT	M16	130 LB-FT	165 LB-FT	210 LB-FT
3/4	185 LB-FT	280 LB-FT	M18	170 LB-FT	240 LB-FT	290 LB-FT

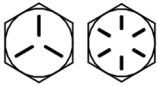
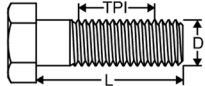
 <p>5-Grade-8</p>	 <p>1/2-13 x 1.75 HHCS</p>	<p>D = Nominal Diameter                      TPI = Threads Per Inch                      P = Pitch (Thread Width, mm)                      L = Length                      X = Description (Hex Head Cap Screw)</p>	 <p>10.9 Class</p>	 <p>M12-1.25 x 50 HHCS</p>
---	--	---	--	--

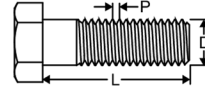

[www.goranco.com](http://www.goranco.com)

Rancho Technical Department 1-800-325-8886.