

INSTALLATION INSTRUCTIONS

RS88029

REV K

FOR RANCHO SUSPENSION SYSTEMS RS6503B: 2006 - 1997 Jeep Wrangler TJ / LJ 2.5-in. Short Arm System*

*The variation between models, and addition of aftermarket bumpers, sliders, winches, etc. will net differences in lift height

READ ALL INSTRUCTIONS THOROUGHLY FROM START TO FINISH BEFORE BEGINNING INSTALLATION



IMPORTANT NOTES!

WARNING: This suspension system will enhance the off-road performance of your vehicle. It will handle differently, both on and off-road, from a factory equipped passenger car or truck. Failure to drive this vehicle safely may result in serious injury or death to the driver and passengers. ALWAYS WEAR your seat belts, REDUCE your speed, and AVOID sharp turns and other abrupt maneuvers.

- A. The vehicle's alignment must be within factory specifications before installing this system. Have the alignment checked at a state approved facility.
- B. Check the frame of the vehicle for any damage or severe corrosion. If there is any structural damage, Do Not install this system
- C. Do not install a body lift kit with Rancho's suspension system or interchange parts from this system with components from another manufacturer. Use the appropriate Rancho shock absorbers. Contact your local Rancho representative for the correct application.
- D. Compare the contents of this system with the parts list in these instructions. If any parts are missing, including fasteners, contact the Rancho Technical Department at 1-800-325-8886. Each hardware kit in this system contains fasteners of high strength and specific size. Do not substitute a fastener of lesser strength or mix one hardware kit with another.
- E. Apply THREAD LOCKING COMPOUND to all bolts during installation. One drop on the exposed threads of each bolt before installing the nut is sufficient to provide an adequate bond. CAUTION: Thread locking compound may irritate sensitive skin. Read warning label on container before use.
- F. Install all nuts and bolts with a flat washer. When both SAE (small OD) and USS (large OD) washers are used in a fastener assembly, place the USS washer against the slotted hole and the SAE washer against the round hole.

G. Unless otherwise specified, tighten all bolts to the standard torque specifications listed at the end of the note's section. Do not use an impact wrench to tighten any of these bolts. They tend to over tighten smaller bolts and under tighten larger bolts. **USE A TORQUE WRENCH!!!**

H. Rancho parts come with a protective coating. Do not chrome, cadmium, or zinc plate any of the components in this kit, or alter their original finish in any way. However, you may add a layer of Enamel paint over the original coating.

I. Do not weld anything to these components, and do not weld any of these components to the vehicle. If any component breaks or bends, contact your local Rancho dealer or Rancho for replacement parts.

J. Some of the service procedures require the use of special tools designed for specific procedures. These special tools should be used when recommended.

K. The following tools and supplies are recommended for proper installation of this kit.

- Jeep Service Manual
- Spring Compressor
- Drill Motor
- 23/64", 15/32", 13/32" and 9/32" Drills
- Torque Wrench (250 FT-LB capacity)
- 1/2" Drive Ratchet and Sockets
- Combination Wrenches
- Allen Wrenches
- Torx Key Sockets
- Heavy Duty Jack stands
- Wheel Chocks (Wooden Blocks)
- Hydraulic Floor Jack
- Large "C" Clamps and or Bench Vise

- Hammer
- Molybdenum Grease or Anti Seize Compound
- Silicone Spray
- Safety Glasses**--Wear safety glasses at all times

L. It is extremely important to replace torsion bars, CV flanges, and front drive shaft/pinion relationships as original. Be sure to mark left/right, front/rear, and indexing of mating parts before disassembly. A paint marker or light colored nail polish is handy for this.

M. Suspension components that use rubber or urethane bushings should be tightened with the vehicle at normal ride height. This will prevent premature failure of the bushing and maintain ride comfort.

N. The required installation time for this system is approximately 5 to 6 hours. Check off the box () at the beginning of each step when you finish it. Then when you stop during the installation, it will be easier to find where you need to continue from.

O. Important information for the end user is contained in the consumer/installer information pack. If you are installing this system for someone else, place the information pack on the driver's seat. Please include the installation instructions when you finish.

P. Thank you for purchasing the best suspension system available. For the best installed system, follow these instructions. If you do not have the tools or are unsure of your abilities, have this system installed by a certified technician. **RANCHO IS NOT RESPONSIBLE FOR DAMAGE OR FAILURE RESULTING FROM IMPROPER INSTALLATION OF THIS SUSPENSION SYSTEM.**

STANDARD BOLT TORQUE SPECIFICATIONS

INCH SYSTEM			METRIC SYSTEM			
Bolt Size	Grade 5	Grade 8	Bolt Size	Class 9.8	Class 10.9	Class 12.9
5/16	15 FT-LB	20 FT-LB	M6	5 FT-LB	9 FT-LB	12 FT-LB
3/8	30 FT-LB	35 FT-LB	M8	18 FT-LB	23 FT-LB	27 FT-LB
7/16	45 FT-LB	60 FT-LB	M10	32 FT-LB	45 FT-LB	50 FT-LB
1/2	65 FT-LB	90 FT-LB	M12	55 FT-LB	75 FT-LB	90 FT-LB
9/16	95 FT-LB	130 FT-LB	M14	85 FT-LB	120 FT-LB	145 FT-LB
5/8	135 FT-LB	175 FT-LB	M16	130 FT-LB	165 FT-LB	210 FT-LB
3/4	185 FT-LB	280 FT-LB	M18	170 FT-LB	240 FT-LB	290 FT-LB

BOLT IDENTIFICATION

<p>1/2-13x1.75 HHCS</p> <p>D T L X</p> <p>Grade 5 Grade 8</p>	<p>M12-1.25x50 HHCS</p> <p>D T L X</p> <p>10.9</p>
<p>G = Grade Marking (bolt strength)</p> <p>D = Nominal Diameter (inches)</p> <p>T = Thread Pitch (threads per inch)</p> <p>L = Length (inches)</p> <p>X = Description (hex head cap screw)</p>	<p>P = Property Class (bolt strength)</p> <p>D = Nominal Diameter (millimeters)</p> <p>T = Thread Pitch (thread width, mm)</p> <p>L = Length (millimeters)</p> <p>X = Description (hex head cap screw)</p>



PARTS LIST

Part Number	Description	Qty
RS6416B	Front Spring Kit	1
RS615B*	Front Coil Spring*	2
RS88116	Instruction RS6416B	1
RS6417B	Rear Spring Kit	1
RS616B*	Rear Coil Spring*	2
RS88117	Instruction RS6417B	1
RS8567	Sub Assy, Bumpstop	1
RS420027	Rear Bumpstop Spacer	2
RS881010BL	TJ Adjustable Lower Control Arm	2
RS881017*	Rod End w/ Bushing, Jam Nut*	1
RS881010BR	TJ Adjustable Lower Control Arm	1
RS881017*	Rod End w/ Bushing, Jam Nut*	1
RS130019	Rear Trackbar Bracket	1
RS860072	Sub Assy, Track Bar	1
RS420026	Sleeve - .750 X .482 X 1.60	1
RS77033	HHCS, 7/16-14 X 1.	1
RS7726	Washer, 7/16 SAE	2
RS78371	Nut 7/16-14 Top Lock	1
RS770051	HHCS, 3/8-16 X 1.0	1
RS603508	Washer, 3/8 SAE	2
RS78391	Nut 3/8-16 Top Lock	1
RS77035	HHCS, 12MMX1.75X70	2
RS7723	Washer, 1/2 SAE	4
RS7911	Nut, 12MM-1.75 Top Lock	2

Part Number	Description	Qty
RS860071	Sub Assy, Shift Relocator	1
RS77032	BHCS, 1/4-20 X .75	4
RS7710	Nut, 1/4-20 Nylock	4
RS77841	Washer 1/4 SAE	4
RS170079	Shift Relocator	1
RS42702	Thread Lock	2
RS860886	Sub Assy, Skid Plate Spacer	1
RS176983	Spacer 1.25"	8
RS420126	Sleeve, 0.527 X 0.625 X 1.188	8
RS770330	SHCS, 1/2-13 X 3.0" Gr.8.	6
RS770072	HHCS 12MM-1.75X60MM Gr 10.9	8
RS7719	Washer 1/2 USS	8
RS88029B	Instructions - RS6503B	1
RS94180	Information Pack	1
RS94177	Rollover Warning Label	1
RS94119	Consumer/Warranty Information	1
RS780281	Rancho Decal	1
R-RM0082-1112	Warranty Tag	1
RS166	Bag 9 X 12 - 1 Mil	1
RS780294	Red Rancho Diecut Decal	1
RS780294B	Black Rancho Diecut Decal	1

*Service Part — may be purchased separately to replace worn components. Contact the Rancho Technical Department at 1-800-325-8886 for replacement.

FRONT SUSPENSION

SHOCK & SPRING REMOVAL

- 1) Park vehicle on a level surface, set the parking brake and chock rear wheels.
- 2) From inside the engine compartment, remove the upper stud nut, retainer and grommet from both front shock absorbers.
- 3) Raise the front of the vehicle and support the frame with jack stands.
- 4) Remove the front wheels.
- 5) Position a hydraulic jack under the front axle for support. Remove the stabilizer link lower nut and bolt from both sides of the front axle. See Illustration 1.

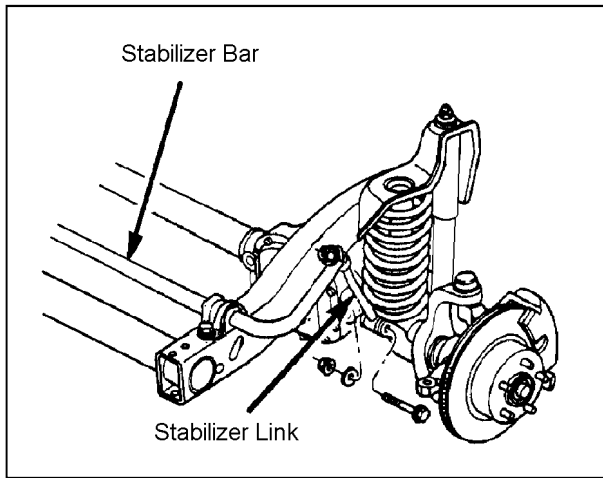

Illustration 1

- 6) Remove the shock absorber lower nuts and bolts from the axle bracket. Remove both shocks and discard. **DO NOT REUSE ORIGINAL SHOCK ABSORBERS.**
- 7) Lower axle and remove hydraulic jack.
- 8) Remove the rubber bump stops and bump stop mounts.
- 9) Remove the coil spring retainer bolts and retainers.
- 10) Push down on the axle and remove each coil spring.

LOWER ARM REPLACEMENT

- 1) Support the front axle with a hydraulic jack.
- 2) Paint or scribe alignment marks on the adjustment cams and axle brackets for installation reference. See Illustration 2.

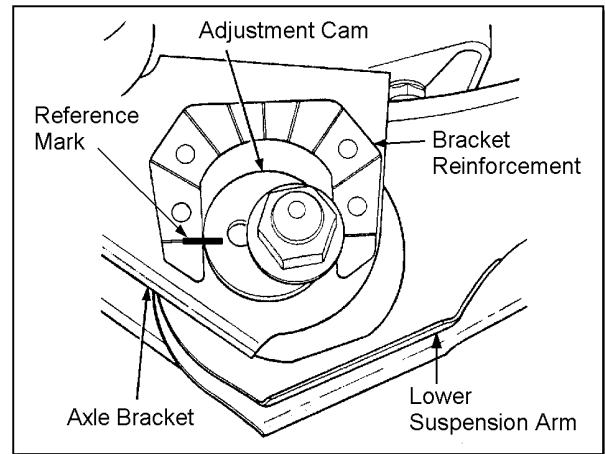

Illustration 2

- 3) If equipped with ABS brakes, remove sensor wires and clamps from the inboard side of the lower arms. Save clamps for reuse.

NOTE: Remove and replace one suspension arm at a time.

- 4) Adjust Rancho lower control arms RS881010BL and RS881010BR to 16.00"
- 5) **CAUTION:** Do not exceed maximum length of 16.32" Exposed thread must be 1-3/16" (1.188") or less. See Illustration 3.



Illustration 3

- 6) Remove the nut, cam, and cam bolt from the axle bracket. Remove the nut and bolt from the frame bracket. Remove the lower suspension arm. See Illustration 4.

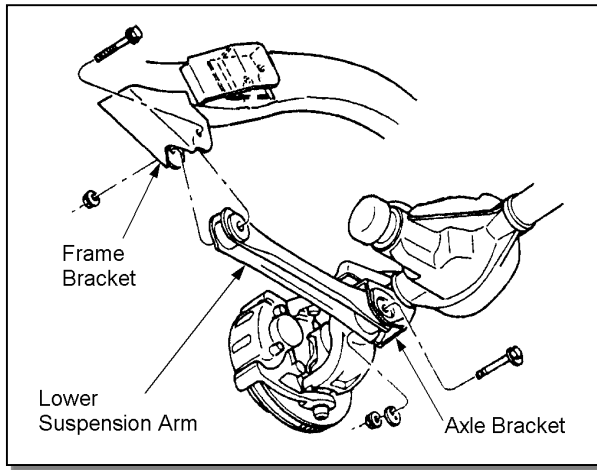

Illustration 4

- 7) Attach the adjustable end of the lower control arm R881010B to the frame bracket with original hardware. See Illustration 5



Illustration 5

- 8) Attach non-adjustable end of lower control arm to the axle bracket with the original hardware.
- 9) If control arms do not align with mounting holes, use a jack under the axle pinion housing or under the differential to slightly rotate axle the desired direction.
- 10) Repeat steps 5 through 8 to install control arm on the passenger side.
- 11) Torque lower control arm mounting hardware to 130 lb-ft. Tighten jam nut to 150 lb-ft.

COIL SPRING AND SHOCK ABSORBER INSTALLATION

- 1) Lower the front axle and remove the hydraulic floor jack.
- 2) Reinstall the rubber bump stop.
- 3) Compress the new front coil spring to 16 inches in length. Use a quality spring compressor like the one shown in Illustration 6.

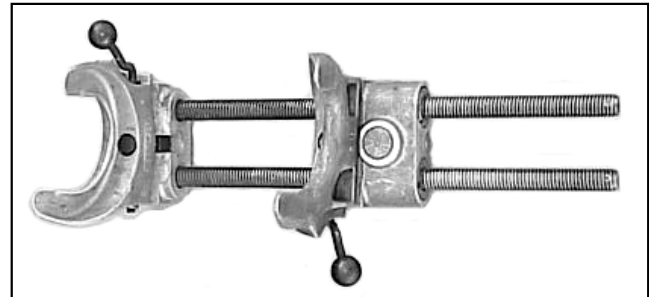

Illustration 6

- 4) Install the spring into the upper and lower spring pockets. Carefully remove the spring compressor.
- 5) Rotate spring so pig tail end fits back in spring pocket.
- 6) Repeat steps 2 through 5 for other side.
- 7) Install one retaining washer and grommet onto each new front shock absorber. Attach shocks to axle brackets. Tighten bolts to 23 FT-LBS.
- 8) Install front wheels and lower vehicle to the ground. Tighten lug nuts to 80--110 FT-LBS.
- 9) Position shock stud through upper mounting hole. Install upper shock grommet, retainer and nut. Tighten to 17 FT-LBS. Repeat for other side.
- 10) Reconnect the stabilizer bar to the front axle. Tighten both lower link bolts to 70 FT-LBS.
- 11) Tighten the lower suspension arm to frame bracket nut and bolt to 130 FT-LBS (both sides).
- 12) Align the reference marks on the adjustment cams and lower arm axle brackets. Tighten nuts to 85 FT-LBS.

REAR SUSPENSION

SHOCK & SPRING REMOVAL

- 1) Chock front wheels.
- 2) Disconnect the stabilizer bar links from the stabilizer bar.
- 3) Disconnect the track bar from the frame bracket. See Illustration 7.
- 4) Raise the rear of the vehicle and support the frame with jack stands. Remove the rear wheels.
- 5) Separate the track bar from the axle bracket. Remove the track Bar. See Illustration 7.
- 6) Support the rear axle with a floor jack and remove the shock absorbers.
- 7) Mark the orientation of the coil springs on the axle pads. Carefully lower the rear axle until the coil springs are free from the upper mount seat. Remove the coil springs.

TRACK BAR BRACKET INSTALLATION

- 1) Place track bar bracket 130019 on top of the axle bracket as shown in figure 8. Insert a 14mm bolt through both brackets. Using the new bracket as a template, mark the two additional holes on the axle bracket.
- 2) Remove bracket and drill holes. Drill a 13/32" hole through the top of the axle bracket and 15/32" hole through the side.

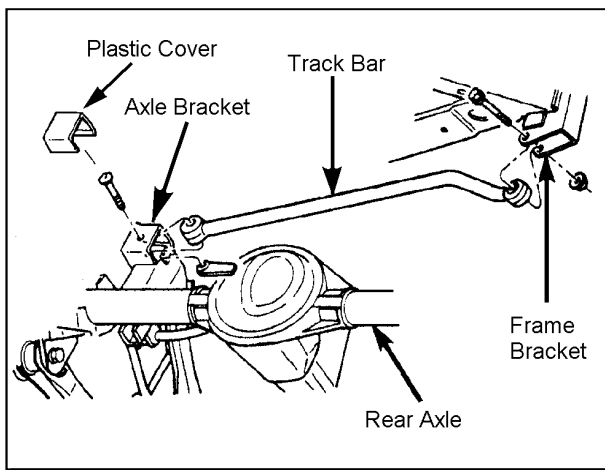

Illustration 7

- 3) Reinstall the track bar bracket and attach it to the axle with the sleeve and hardware from kit 860072. See Illustration 8. Tighten to specifications.
- 4) Insert track bar into track bar bracket and install the 14mm hardware from kit 860072. Do not tighten.
- 5) Raise the rear axle and position the track bar into the frame bracket. Loosely install the original hardware.
- 6) Bend gas tank skid plate away from track bar if necessary.

LOWER ARM REPLACEMENT

NOTE: Remove and replace one suspension arm at a time.

- 1) Support the rear axle with a hydraulic jack.
- 2) Adjust Rancho lower control arms RS881010BL and RS881010BR to 16.00".

CAUTION: Do not exceed maximum length of 16.32"
Exposed thread must be 1-3/16" (1.188") or less. Refer back to Illustration 1.

- 3) Remove the lower arm axle and frame mounting bolts. Remove the lower suspension arm.
- 4) Attach the adjustable end of the lower control arm R881010B to the frame bracket with original hardware. See Illustration 9.

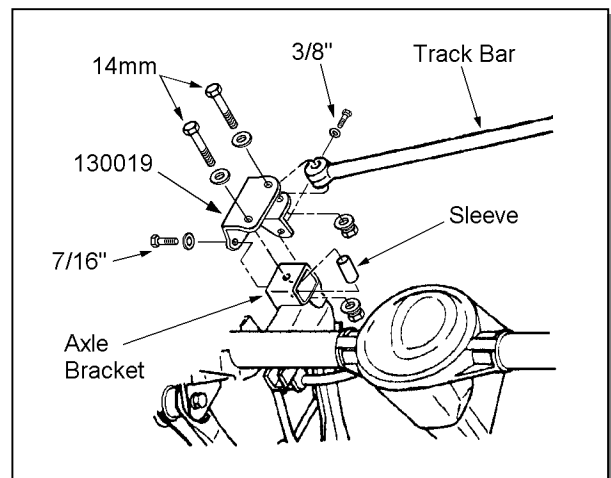

Illustration 8

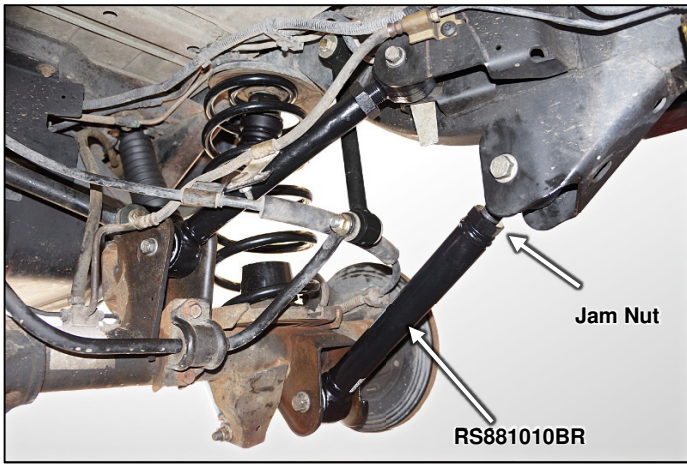

Illustration 9

- 5) Attach non-adjustable end of lower control arm to the axle bracket with the original hardware.
- 6) If control arms do not align with mounting holes, use a jack under the axle pinion housing or under the differential to slightly rotate axle the desired direction.
- 7) Repeat steps 3 through 6 to install control arm on the passenger side.
- 8) Torque lower control arm mounting hardware to 130 lb-ft. Tighten jam nut to 150 lb-ft.

BUMP STOP SPACER & COIL SPRING INSTALLATION

- 1) Remove the rubber bump stop and bump stop bracket from the upper spring mount.
- 2) Insert a Rancho spacer from kit 8567 and reinstall the bracket with the 10mm hardware from kit 860073. See Illustration 10.
- 3) Insert the bump stop into the bump stop bracket. Repeat steps 1 through 3 for other side.

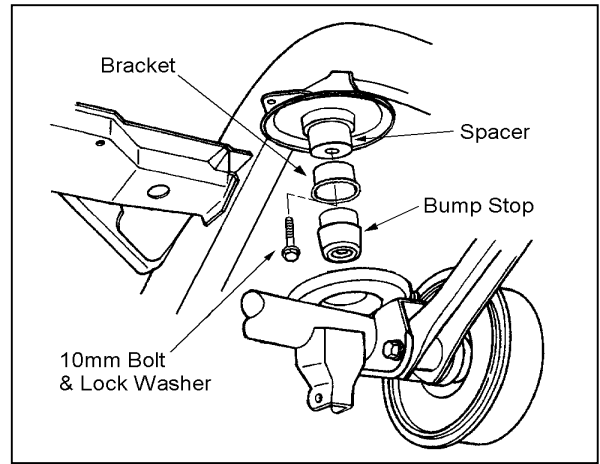

Illustration 10

- 4) Lower rear axle and position the new coil springs RS616B onto the axle pads. Align springs with reference marks. Raise the axle until the spring seats in the upper mount.
- NOTE:** When installing coil springs, make sure that the rubber damper is positioned in the upper mount and the small egg-shaped coil end is at the top.
- 5) Install new Rancho rear shocks to the upper frame rail. Tighten mounting bolts to 23 FT-LBS.
 - 6) Attach shocks to the axle brackets loosely.
 - 7) Install wheels and lower vehicle to the ground. Do not remove wheel chocks. Tighten lug nuts to 80—110 FT-LBS.
 - 8) Tighten the lower shock mounting bolts and the track bar mounting bolts to 74 FT-LBS.
 - 9) Reconnect stabilizer bar links. Tighten nuts/bolts to 40 FT-LBS.
 - 10) Tighten all lower arm mounting nuts to 130 FT-LBS.

TRANSMISSION & TRANSFER CASE

CROSSMEMBER RELOCATION

1) If applicable, remove the bolts attaching the automatic transmission skid plate to the frame rails and the transfer case crossmember. Remove the skid plate.

NOTE: The OE automatic transmission skid plate cannot be used with this suspension system.

2) Place the transmission in neutral. Support the transfer case crossmember/skid plate with a hydraulic jack. Loosen the 6 bolts holding the crossmember to the frame. See Illustration 11.

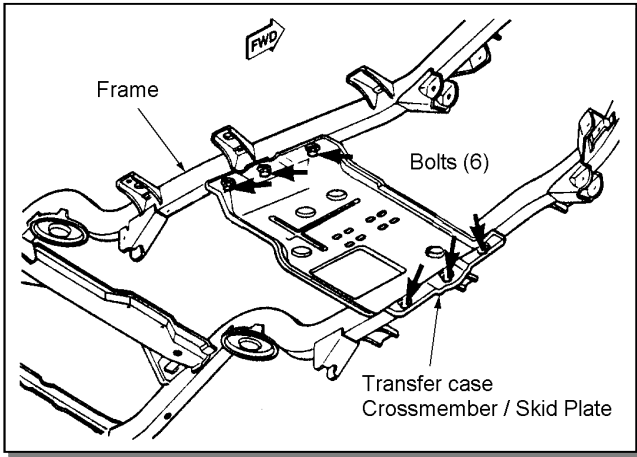

Illustration 11

3) Remove 3 bolts on one side and carefully lower the crossmember/skid plate.

4) Place 3 spacers with sleeves from kit RS860886 between the crossmember. See Illustration 12 and Illustration 13.

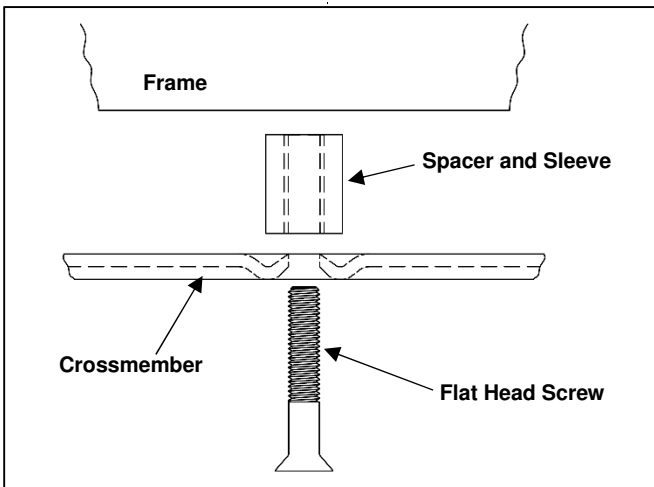

Illustration 12

5) Apply thread lock and insert the appropriate screws through the crossmember, spacers, and into the frame. See Illustration 12 and Illustration 13.

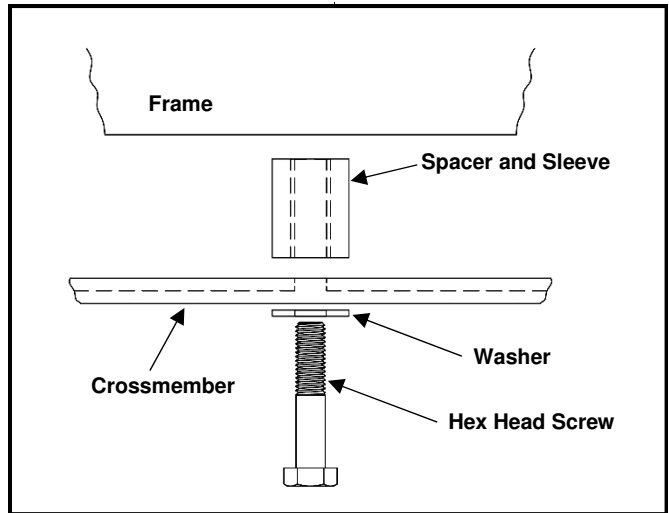

Illustration 13

6) Repeat steps 3 through 5 for the other side of the crossmember. Tighten all bolts to 45 FT-LBS.

LINKAGE RELOCATION & ADJUSTMENT

1) Pull back carpet/mat to gain access to torque shaft bracket mounting screws. If necessary, loosen the screws attaching the console to the floor panel.

2) Remove the four screws that attach the torque shaft bracket to the floor pan. See Illustration 14.

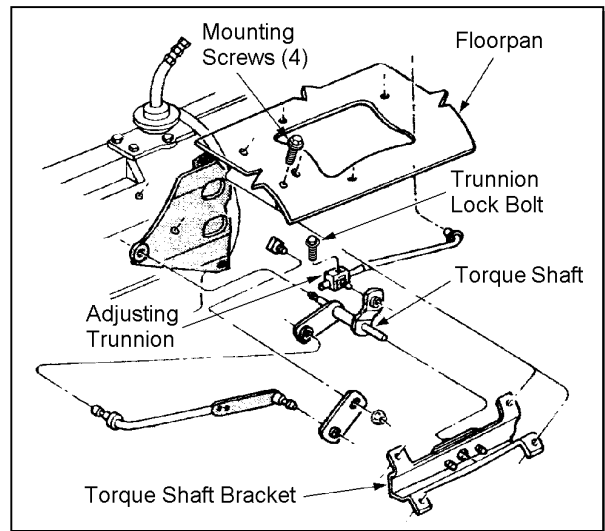

Illustration 14

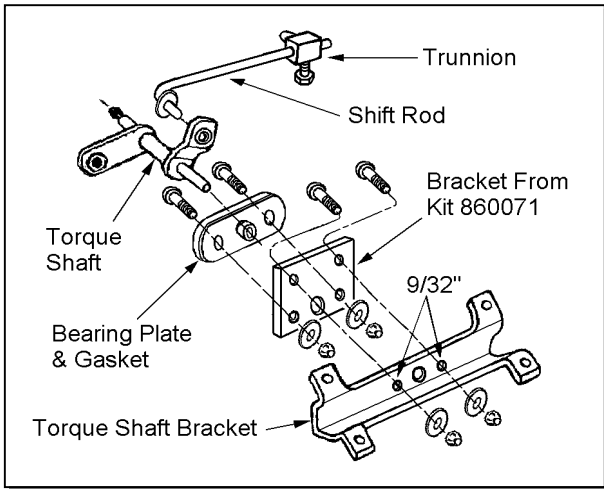

Illustration 15

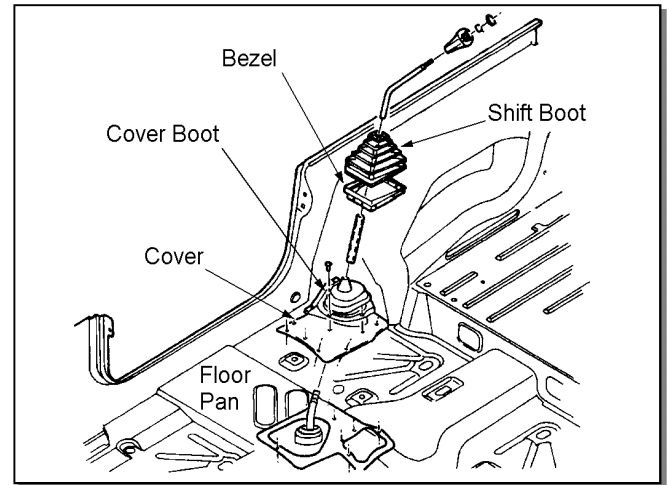

Illustration 16

3) Slide the torque shaft bracket off the torque shaft, and remove the bearing plate & gasket. Drill out the two threaded holes in the torque shaft bracket to 9/32".

4) Attach the shift relocating bracket (from kit 860071) to the torque shaft bracket as shown in Illustration 15. Use the hardware from kit 860071.

5) Attach the bearing plate, with gasket, to the shift relocating bracket. See Illustration 15.

6) Insert the torque shaft into the bearing plate and reinstall the torque shaft bracket to the floor pan. Verify that the torque shaft is level and the shifting linkage moves without restriction. If necessary, file the end of the shift rod to provide adequate clearance.

7) Shift transfer case into 4L position and loosen lock bolt on adjusting trunnion.

NOTE: Be sure shift rod slides freely in trunnion.

8) Verify that transfer case range lever is fully engaged in 4L position. Tighten adjusting trunnion lock bolt.

9) Reinstall carpet/mat and tighten console mounting bolts.

FLOOR PAN MODIFICATION (MANUAL TRANS ONLY)

1) Move the seats to the full rearward position.

2) Pry up the shift boot and bezel from the floor console. See Illustration 16.

3) Remove the bolts attaching the console to the floor pan.

4) Lift the console upward and remove through the passenger door.

5) Remove the 4 screws attaching the cover boot to the cover. Slide the boot upward to expose the opening in the cover and floor pan.

6) Shift the transmission into 2nd and reverse. Verify a minimum of 1/8" clearance between the shift lever and floor pan. If necessary, enlarge the opening in the floor pan with a half round file.

7) Reposition the cover boot. Install one screw on the left side or 9 o'clock position.

8) Rotate the boot clockwise to match the increased floor pan opening. Mark and drill the three new mounting holes. See Illustration 17



Illustration 17

9) Reinstall the cover boot, console, and shift boot.

FINAL CHECKS AND ADJUSTMENTS

10) Turn the front wheels completely left then right. Verify adequate tire, wheel, and brake hose clearance. Inspect steering and suspension for tightness and proper operation.

11) With the suspension at maximum extension (full droop), inspect and rotate all axles and drive shafts. Check for binding and proper slip yoke insertion. The slip yoke should be inserted a minimum of one inch into the transfer case and/or transmission.

12) Ensure that the vehicle brake system operates correctly. If new brake hoses were installed, verify that each hose allows for full suspension movement.

13) Readjust headlamps. Have vehicle Aligned at a certified alignment facility.

ADJUSTMENT	PREFERRED	RANGE
Caster	7°	±1.0°
Camber (fixed angle)	-0.25°	±0.63°
Toe-In (each wheel)	0.15°	±0.15°
Thrust Angle	0	±0.15°

Please retain this publication for future reference. See Important Note O.

 NOTES:



<http://www.goranchocom/>

Rancho Technical Department 1-800-325-8886.